

**Precautions** (Please be sure to read before use.)

<b>⊘ Do Not</b>
<ol style="list-style-type: none"> <li>1. This product uses ordinary off-the-shelf electronic components, and is therefore inappropriate for use in applications that require special quality or reliability and are expected to protect human lives or prevent accidents, such as safety mechanisms in fields including space, aeronautics, medicine, and nuclear power.</li> <li>2. Do not be used underwater or in high-humidity environments.</li> <li>3. Do not be used in the presence of corrosive gases, combustible gases, or other flammable gases.</li> <li>4. Do not turn on power when circuit board surface is in contact with other metal.</li> <li>5. Do not apply voltage higher than rated voltage.</li> </ol>
<b>⚠ Attention</b>
<ol style="list-style-type: none"> <li>6. This manual may be revised in the future without notice owing to improvements.</li> <li>7. All efforts have been made to produce the best manual possible, but if users notice an error or other problem, we ask that they notify us.</li> <li>8. Item 7 notwithstanding, HuMANDATA cannot be held liable for the consequences arising from use of this product.</li> <li>9. HuMANDATA cannot be held liable for consequences arising from using this product in a way different from the uses described herein, or from uses not shown herein.</li> <li>10. This manual, circuit diagrams, sample circuits, and other content may not be copied, reproduced, or distributed without permission.</li> <li>11. If the product emits smoke, catches fire, or becomes unusually hot, cut the power immediately.</li> <li>12. Do not install the control cables or communication cables together with the main circuit lines or power cables. In such an environment, it may result in malfunction due to noise.</li> <li>13. Be careful of static electricity.</li> </ol>

**1. Revision History**

Date	Revision	Description
Dec. 11, 2014	1.0	Initial release
Mar. 24, 2016	1.1	Revise: Section "Block Diagram" Revise: Section "Specifications"
Sep. 03, 2024	1.2	Correct: typo
Jan. 30, 2025	1.3	Correct: typo

**2. Product packaging**

Thank you very much for purchasing the USB-003. In this package, you will find the following items included. If there are any shortages or issues, please contact us.

- USB to RS-485/422 Converter Compact USB-003 1
- USB cable (1.8m) 1
- Driver & Application CD 1

**3. Introduction**

Thank you very much for purchasing our product of USB-003. USB-003 is a USB to RS-485/RS422 converter that isolated between RS-485/422 and a USB port. So, it's safe for use in factory automation environment.

**4. Block Diagram**

Between USB and RS-485/422 are isolated.

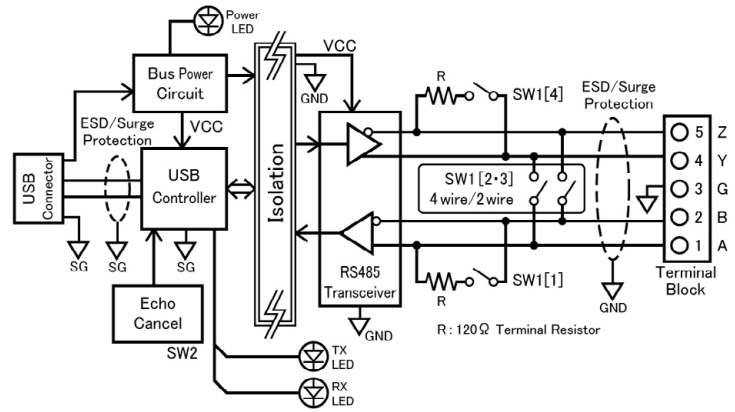

**5. Overview**

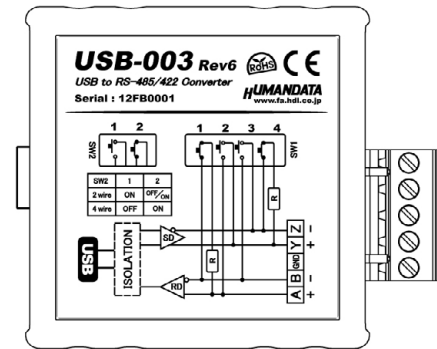

TOP side (Block diagram)

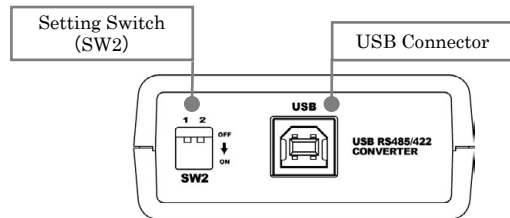

Front Side (USB)

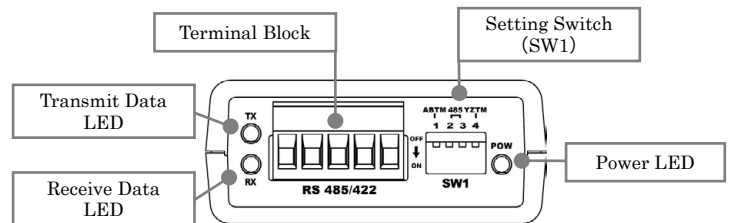

Rear Side (RS-485/422)

**6. Power Supply**

USB-003 is powered through a USB port (Bus-powered). No external power supply is required.

## 7. Product Specification

Item	Description	Remarks
Model	USB-003	
Input Power	5VDC Supplied through a USB port (Bus-powered)	No external power supply required
Current Consumption	Less than 100 mA	
I/O Interface	RS-485/RS422 (2-wire or 4-wire)	ESD protection ±15KV
HOST interface	USB 2.0 Compliant (Support Full Speed)	USB 1.1 compatible ESD protection
Baud Rate	300 bps to 250 Kbps	Support custom baud rate
Data Bits	7 or 8 bit	
Stop Bits	1 or 2 bit	
Parity	Even, Odd, No-parity	
FIFO RX Buffer Size	384 bytes	
FIFO TX Buffer Size	128 bytes	
Isolation Method	Bus isolation	
Isolation Protection	2000VDC	Designed value
Processor	FT232BL	FTDI
USB Driver	Virtual COM port driver	
Supports OS	Windows 11/10/8.1/8/7	
LED	POW: USB bus power RX: Receive data TX: Transmit data	
USB connector	Standard Type B Female	
RS-485/422 Connector	Detachable the screw terminal 5pin	PHOENIX CONTACT
Operating Ambient temp.	-10 to 60 °C (14 to 140 [°F])	No condensation permitted
Operating Ambient Humidity	30 to 85 %RH	
Storage Ambient temp.	-20 to 55 °C (-4 to 131 [°F])	
Storage Ambient Humidity	30 to 85 %RH	
Compliance to Standards	CE	
Weight	Approx. 90 [g]	Only main body
Dimensions	67 x 67 x 28 [mm] (2.638" x 2.638" x 1.102")	Without projections

\* There is a case to be changed to the parts of the compatibility.

\* Power saving function (suspend, standby, sleep and others) is not supported.

[CE marking]

USB-003 has applied the common standard for heavy industrial environment  
EN61000-6-2 and EN61000-6-4.

--- Application of the standards ---

EMS: EN61000-6-2

· IEC61000-4-2 Electrostatic discharge requirements

· IEC61000-4-3 Radiated electromagnetic field requirements

· IEC61000-4-4 Electrical fast transient burst requirements





· IEC61000-4-5 Surge immunity test requirements

· IEC61000-4-6 Conducted radio frequency requirements

EMI: EN61000-6-4

· CISPR11 Group 1 Class A Emissions

## 8. Optional Accessories

Model	Image	Description
PEN-003		Attachment with clamping screw JAN : 4937920800709
PEN-003-DIN		Attachment for 35mm DIN rail JAN : 4937920800716
PEN-003-MG		Attachment with neodymium magnet JAN : 4937920801201
ACC-005		5P Terminal to RJ45 Convert Adapter JAN : 4937920800730
TB-USB-5		Detachable 5P Terminal Connector 1757048 (Phoenix Contact) JAN : 4937920800747

## 9. RS-485/422 (4 wire) Mode

Item	Specification	Remarks
Comm. Method	Full-duplex transmission	
Baud Rate	300 bps to 250 Kbps	Custom baud rate is supported
Number of Connectable Terminals	128	Typical example
Terminal Resistor	120 Ω	Configurable by setting switch (SW1) ON/OFF
Transmit Enable Control	Automatically controlled by USB controller	
Receive Enable Control	Available by setting switch (SW2)	

RS-422 or RS-485 mode can communicate with multiple terminals by using two twist pair cables. Wires of upstream and downstream are separated and simultaneous communication (full-duplex transmission) is available.

## 10. RS-485 (2 wire) Mode

Item	Specification	Remarks
Comm. Method	Half-duplex transmission	
Baud Rate	300 bps to 250 Kbps	Custom baud rate is supported
Number of Connectable Terminals	128	Typical example
Terminal Resistor	120 Ω	Configurable by setting switch (SW1) ON/OFF
Transmit-Receive Switching	Automatically controlled by USB controller	
Echo Cancellation	Available by setting switch (SW2)	

RS-485 mode can communicate with multiple terminals by using a twist pair cable.

## 11. Interface Terminal

Terminal block is pluggable. Do not remove it while the power is supplied.

Pin Number	Signal	Signal and Polarity
1	A	RD+
2	B	RD-
3	GND	GND
4	Y	SD+
5	Z	SD-

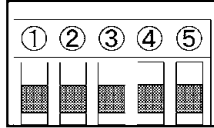

The GND(Ground) pin is recommended to be wired.

## 12. Setting Switch

By setting SW1 and SW2, USB-003 can change operating mode, switching echo cancelling and terminal resistor.

### 12.1. RS-485/422 (4 wire)

SW2		
	1	2
4 wire	OFF	ON

\* Please refer to Section 12.3

**Factory Setting**

SW1				
	1	2	3	4
No termination	OFF	OFF	OFF	OFF

SW1				
	1	2	3	4
Transmit Side termination	OFF	OFF	OFF	ON

SW1				
	1	2	3	4
Receive Side termination	ON	OFF	OFF	OFF

SW1				
	1	2	3	4
Both Sides termination	ON	OFF	OFF	ON

### 12.2. RS-485 (2 wire)

- Echo Cancelling Enable (no echo)

SW2		
	1	2
2 wire	ON	OFF

\* Please refer to Section 12.3

SW1				
	1	2	3	4
No termination	OFF	ON	ON	OFF

SW1				
	1	2	3	4
Termination Enable	ON	ON	ON	OFF

- Echo Cancelling Disable (echo enable)

SW2		
	1	2
2 wire	ON	ON

## 12.3. Setting Switch (SW2) Function

SW2-1	DE (transmit enable) Control
OFF	Always Enable
ON	Enable in Transmission

SW2-2	Echo Control
OFF	Echo Cancelling Enable (no echo)
ON	Echo Cancelling Disable (echo enable)

## 13. Latency Timer

In some cases, adjusting “Latency Timer” will help to speed up the response time of application. The default value is set by device driver.

If you reduce the value of “Latency Timer”, its priority will be higher. But be careful that the response time of the other applications will probably be slow.

Following steps of Windows OS show how to set “Latency Timer”.  
Open “Device Manager” and right click “[USB-003/010/017...]”.  
Open “Properties” window and open “Port Setting” tab, then click “Advanced” button.

## 14. Additional Documentation and User Support

The following documents and other supports are available at

- Product Documents:  
<https://www.hdl.co.jp/en/faspc/USB/usb-003/>
- Support Center:  
<https://www.fa.hdl.co.jp/en/support.html>

## 15. Warranty and Compensation

Please refer to the following URL for the warranty.

<https://www.fa.hdl.co.jp/en/fa-warranty.html>

## 16. Contact us

Please contact us using the inquiry form on our company's website or email us at [SPC2@hdl.co.jp](mailto:SPC2@hdl.co.jp), providing the product model number and serial number.

## HuMANDATA LTD.

Address 1-2-10-2F, Nakahozumi, Ibaraki Osaka, Japan ZIP 567-0034

TEL 81-72-620-2002 (Japanese)

FAX 81-72-620-2003 (Japanese/English)

URL <https://www.fa.hdl.co.jp> (Japan)

<https://www.fa.hdl.co.jp/en/> (Global)