

**RS-485 LAN Converter for Modbus**  
**[Economy type]**

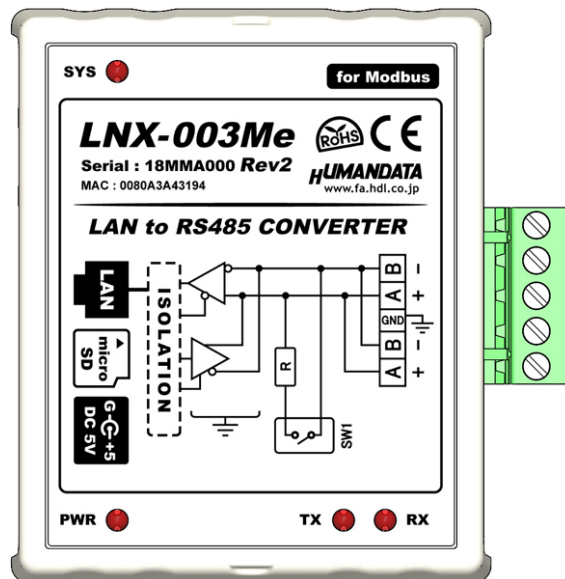

**LNx-003Me (Rev2)**

**User's Manual**  
**Ver. 1.1**



**HUMANDATA LTD.**



# Table of Contents

● Precautions.....	1
● Revision History .....	2
● Introduction.....	2
1. Product Configuration.....	2
2. Part Names and Functions .....	3
3. Specifications.....	5
3.1. Product Specification.....	5
3.2. AC adapter.....	7
3.3. Optional Accessories .....	7
3.4. Power Supply.....	8
3.5. RS-485 (2-wire).....	8
4. Interface Terminal .....	8
5. Setting Switch for Terminal Resistor .....	8
6. Connection examples .....	9
7. Setting Tool.....	11
7.1. Access Flow of microSD card.....	12
7.2. Function.....	13
7.3. Write Setting Data .....	17
7.4. Read Setting Data.....	19
7.5. Write or Read setting data over the network.....	21
7.6. Setting Example.....	22
8. Factory Setting (default value).....	26
9. Virtual COM Port .....	27
10. Additional Documentation and User Support.....	27
11. Attachment Documentations.....	27
12. Warranty and compensation .....	27

● **Precautions**

 <b>Do Not</b>	1	This product uses ordinary off-the-shelf electronic components, and is therefore inappropriate for use in applications that require special quality or reliability and are expected to protect human lives or prevent accidents, such as safety mechanisms in fields including space, aeronautics, medicine, and nuclear power.
	2	Do not be used underwater or in high-humidity environments.
	3	Do not be used in the presence of corrosive gases, combustible gases, or other flammable gases.
	4	Do not turn on power when circuit board surface is in contact with other metal.
	5	Do not apply voltage higher than rated voltage.

 <b>Attention</b>	6	This manual may be revised in the future without notice owing to improvements.
	7	All efforts have been made to produce the best manual possible, but if users notice an error or other problem, we ask that they notify us.
	8	Item 7 notwithstanding, HuMANDATA cannot be held liable for the consequences arising from use of this product.
	9	HuMANDATA cannot be held liable for consequences arising from using this product in a way different from the uses described herein, or from uses not shown herein.
	10	This manual, circuit diagrams, sample circuits, and other content may not be copied, reproduced, or distributed without permission.
	11	If the product emits smoke, catches fire, or becomes unusually hot, cut the power immediately.
	12	Do not install the control cables or communication cables together with the main circuit lines or power cables. In such an environment, it may result in malfunction due to noise.
	13	Be careful of static electricity.

## ● Revision History

Date	Revision	Description
Jun. 9, 2022	v1.0	Initial release
Nov. 7, 2024	v1.1	Correct: typo

## ● Introduction

Thank you for purchasing our product RS-485 LAN Converter for Modbus economy type LNX-003Me.

LNX-003Me can convert protocols from Modbus TCP to Modbus RTU/ASCII. LNX-003Me can connect Modbus devices over Ethernet by acting as masters or slaves. Although Modbus can be used for both serial and Ethernet devices, protocol conversions are also required to interconnect, because not only the physical connection of serial and Ethernet communications, but also the protocol is different. LNX-003Me allows you to integrate Modbus TCP and Modbus RTU/ASCII networking. LNX-003Me is an economy model of LNX-003M from which only PoE function is removed.

LNX-003Me has obtained the CE marking.

## 1. Product Configuration

The following lists the product configuration of the LNX-003Me.

RS-485 LAN Converter for Modbus economy type (LNX-003Me)	1
microSD card with USB adapter	1
AC adapter (DC5V)	1
Driver & Application CD	1

## 2. Part Names and Functions

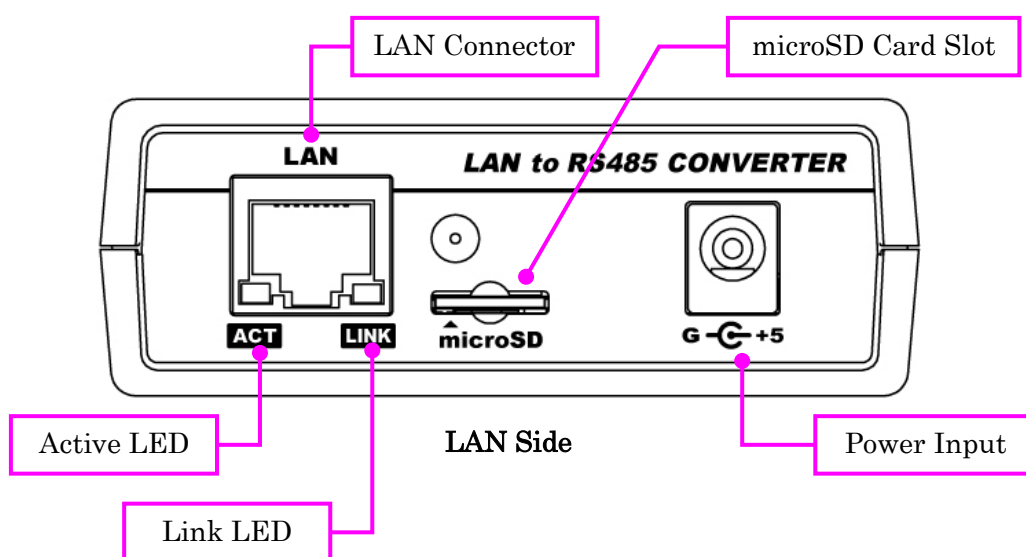
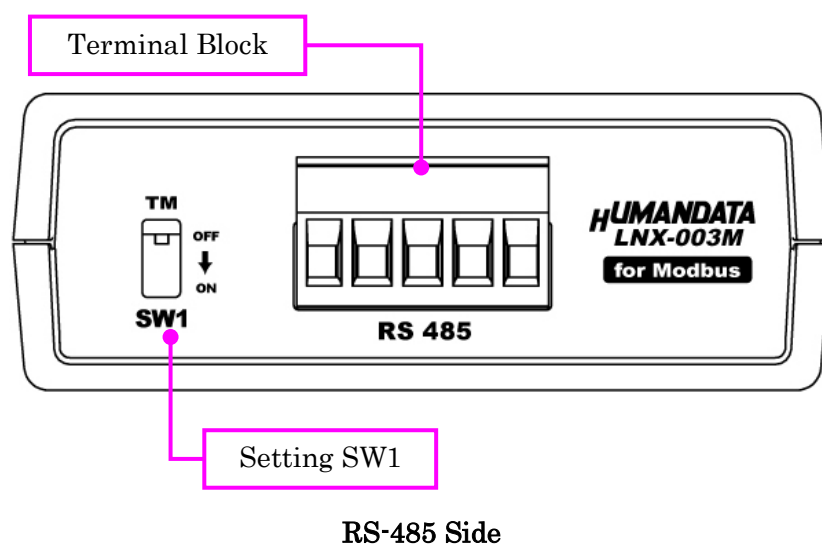

### LEDs

	Name (color)	Function
ACT	Active LED (green)	Turn on during network port communication.
LINK	Link LED (yellow)	Turn on when LNX-003Me is powered and LAN cable is connected normally.

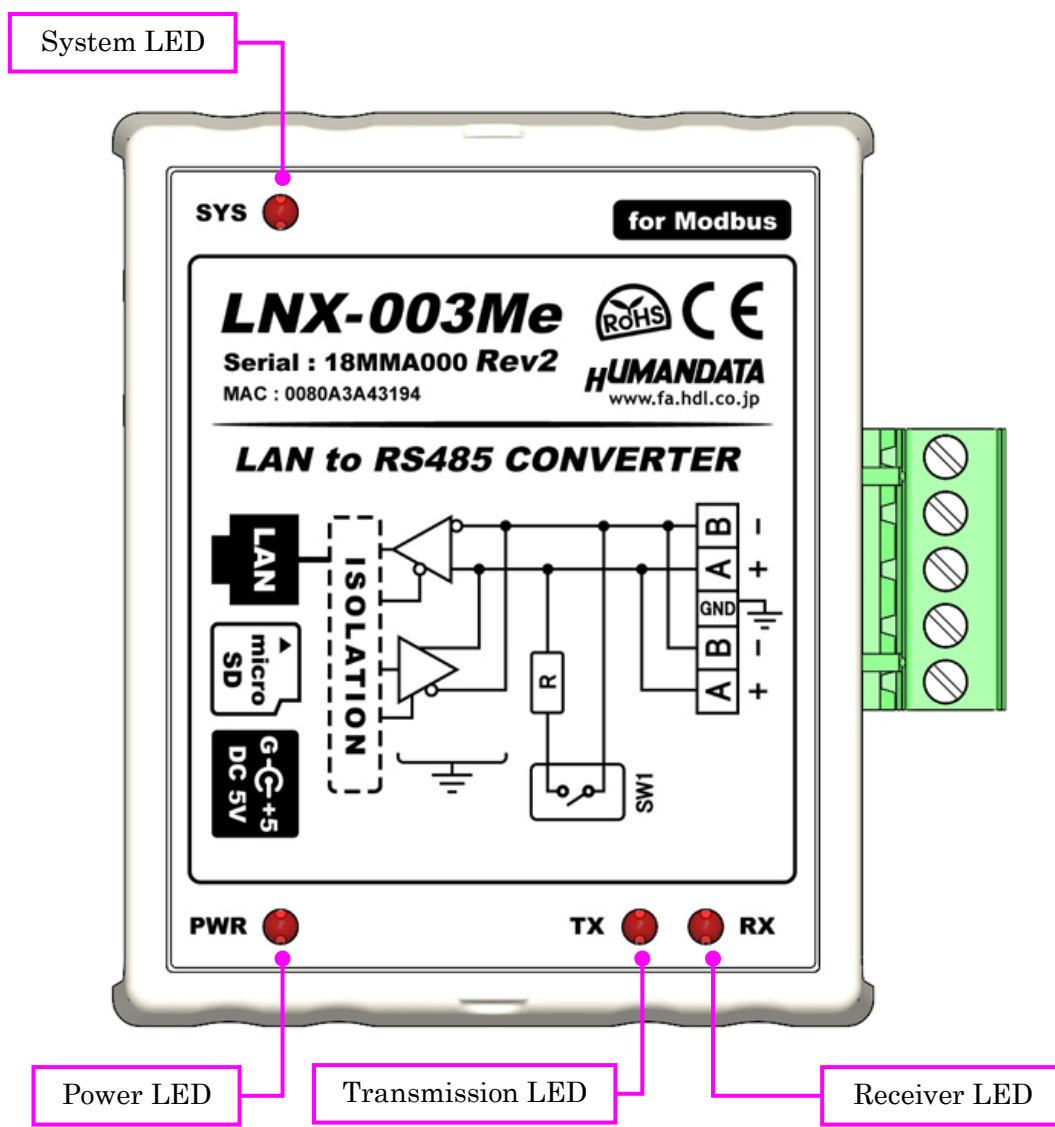

TOP Side

LEDs

	Name (color)	Function
SYS	System LED (red)	Blink few seconds during reading process. Turn on when system is ready.
PWR	Power LED (red)	Turn on when the power is supplied to the LNX-003Me.
TX	Transmission LED (red)	Turn on when data are transmitted to RS485 side.
RX	Reception LED (red)	Turn on when data are received from RS485 side.

## 3. Specifications

### 3.1. Product Specification

Item	Description	Remarks
Model	LNX-003Me	
Power	5VDC Supplied by AC adapter	
Current Consumption	Less than 350mA	
Network Interface	IEEE802.3 (10Base-T) IEEE802.3u (100Base-TX) half-duplex / full-duplex (auto detected)	
LAN Connector	RJ45	ESD protection $\pm 11\text{KV}$ isolation over 1500Vrms
Protocol	Modbus TCP	
Interface	RS485 (2-wire) isolated from inner circuit (DC3000V)	ESD protection $\pm 15\text{KV}$
Connector	5 position Terminal Block (PHOENIX CONTACT)	5.08mm pitch
Setting Memory Card	microSD card	for setting use SPI mode
Baud Rate	300, 600, 1200, 2400, 4800, 9600, 19200, 38400, 57600, 115200 bps	
Data Bits	7 or 8 bits	
Stop Bits	1 or 2 bits	
Parity	Even, Odd, No parity	
Mode	Modbus RTU Master/Slave Modbus ASCII Master/Slave	
Number of connectable devices	Up to 8 Modbus TCP masters can be connected simultaneously	Slave Mode
Slave address - IP address table	Up to 8 IP addresses can be registered for each slave address (ID) range	Master Mode
LED	PWR: Power LED RX: Reception LED TX: Transmission LED SYS: System Status LED LINK (RJ45 Connector): LINK Status ACT (RJ45 Connector): ACT Status	



Item	Description	Remarks
Operating Ambient Temperature	-10 to 55 °C	No condensation permitted. Except AC adapter
Operating Ambient Humidity	30 to 85 % RH	
Storage Ambient Temperature	-20 to 60 °C	
Storage Ambient Humidity	30 to 85 % RH	
Applicable standards	CE	Except for PoE function
Weight	approx. 120 [g]	Only main body
Dimensions	69 x 82.5 x 30 [mm] 2.717" x 3.248" x 1.181"	Without projections
RoHS Compliance	YES	

\* There may be cases that these parts and specifications are changed.

\* Power saving function (suspend, standby, sleep and others) is not supported.

\* Please use the microSD card that comes with the product.

[CE marking]

LNX-003Me have applied the common standard for industrial environment EN61000-6-2 and EN61000-6-4.

--- Application of the standards ---

EMS: EN61000-6-2

- EN61000-4-2(2009) Electrostatic discharge requirements
- EN61000-4-3(2010) Radiated electromagnetic field requirements
- EN61000-4-4(2010) Electrical fast transient burst requirements
- EN61000-4-5(2006) Surge immunity test requirements
- EN61000-4-6(2009) Conducted radio frequency requirements

EMI: EN61000-6-4





- EN61000-6-4(2007)+A1(2011) Radiated Emissions
- EN61000-6-4(2007)+A1(2011) Conducted Emissions

### 3.2. AC adapter

Item	Description	Remarks
Input	AC 100 to 240 V 50 / 60Hz 0.3A	
Output	5VDC 2.0A	
Plug	2.1mm inner diameter	Positive Tip
Compatible DC Jack	2.1mm inner diameter	
Operating Ambient Temperature	0 to 40 °C	No condensation permitted
Operating Ambient Humidity	30 to 85 % RH	
Storage Ambient Temperature	-20 to 80 °C	
Storage Ambient Humidity	10 to 95 % RH	
Wire Length	1.6m	
Weight	approx. 70 [g]	
Dimensions	46 x 34 x 25 [mm] 1.811" x 1.339" x 0.984"	Without projections

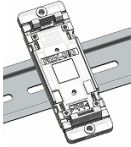
\* There may be cases that this part and specifications are changed.

### 3.3. Optional Accessories

Model Name	Image	Description
PEN-003		Attachment with clamping screw JAN:4937920800709
PEN-003-DIN		Attachment for 35mm DIN rail JAN:4937920800716
PEN-003-MG		Attachment with neodymium magnet JAN:4937920801201
ACC-005		5P Terminal to RJ45 Convert Adapter JAN:4937920800730
TB-USB-5		Detachable 5P Terminal Connector: 1757048 (PHOENIX CONTACT) JAN:4937920800747

### 3.4. Power Supply

LNX-003Me is an economy model of LNX-003M from which PoE function is removed.  
 LNX-003Me requires AC adapter for power supply.

### 3.5. RS-485 (2-wire)

Item	Specification	Remarks
Comm. System	Half-duplex communication	
Baud Rate	300 to 115200 bps	
Number of Connectable Terminals	128	Typical example
Termination Resistor	120 Ω	Configurable by setting switch (SW1) ON/OFF
Transmit-Receive Switching	Automatically controlled	

RS-485 mode can communicate with multiple terminals by using a twist pair cable.

## 4. Interface Terminal

Terminal block is detachable. Do not remove it while the power is supplied.

Pin Number	Signal	Signal and Polarity
1	A (+)	RS485 Data +
2	B (-)	RS485 Data -
3	GND	Signal ground
4	A (+)	RS485 Data +
5	B (-)	RS485 Data -

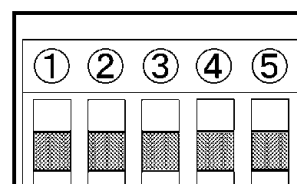

The GND (Ground) pin is recommended to be wired.

Pin 1-4 and 2-5 are internally connected.

## 5. Setting Switch for Terminal Resistor

You can switch the setting of terminal resistor by setting SW1.

SW1	OFF	ON
Terminal Resistor (120 Ω)	disabled	enabled

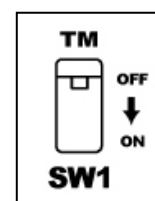

## 6. Connection examples

[LNX-003Me Slave Mode]

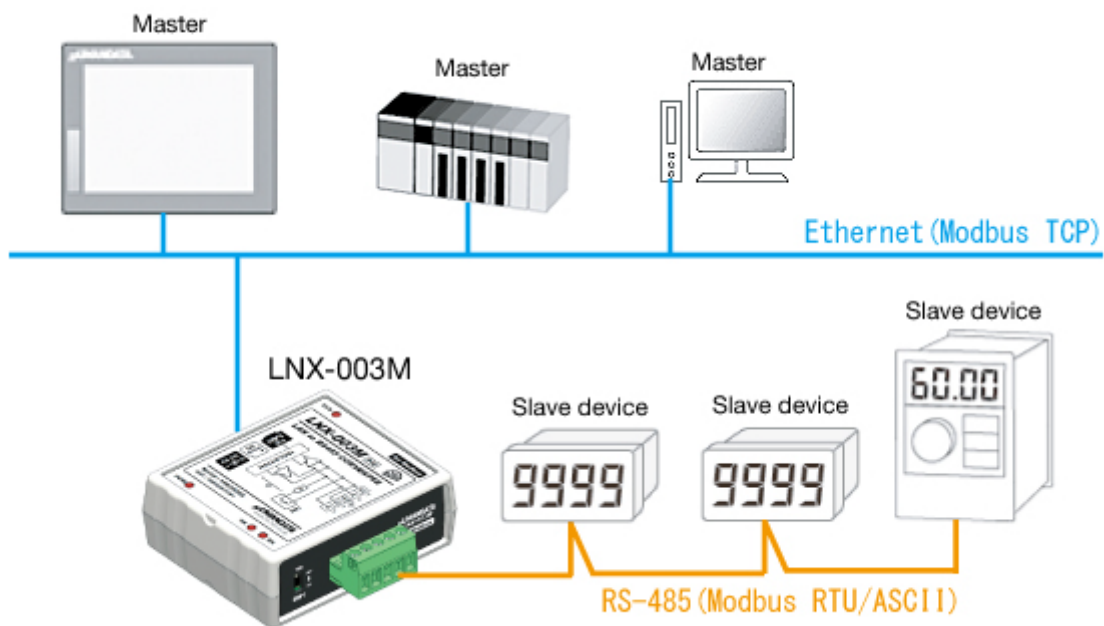

You can control remote Modbus RTU/ASCII slave devices via Ethernet. If the master is a PC, the IP address assigned to the LNX-003Me can also be used by assigning it to the virtual COM port.

[LNX-003Me Master Mode]

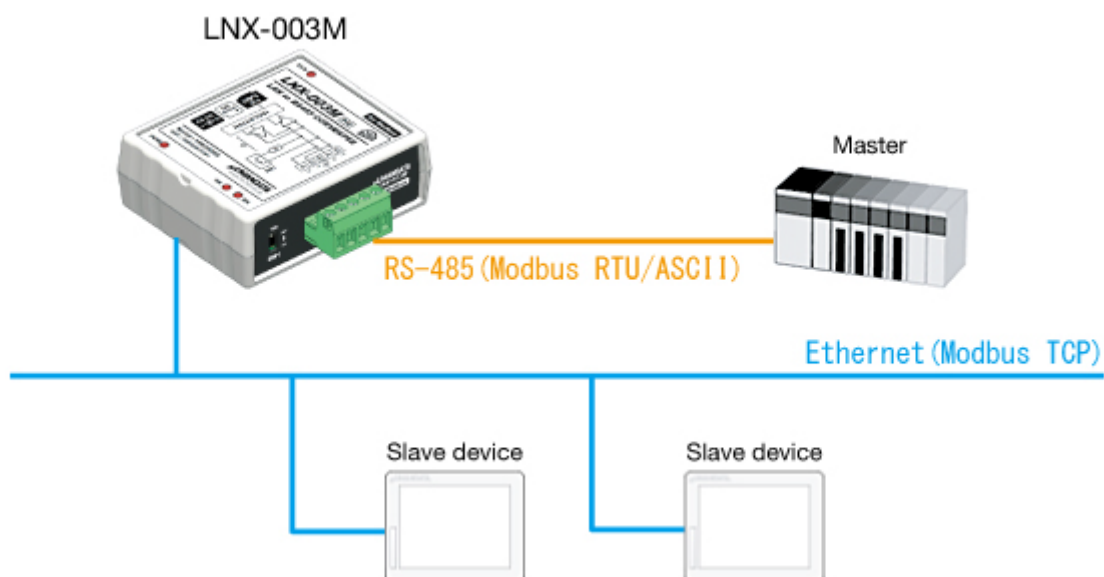

Modbus RTU/ASCII master device can communicate with remote Modbus TCP slave device via Ethernet.

[Tunneling mode between each LNX-003MeS]

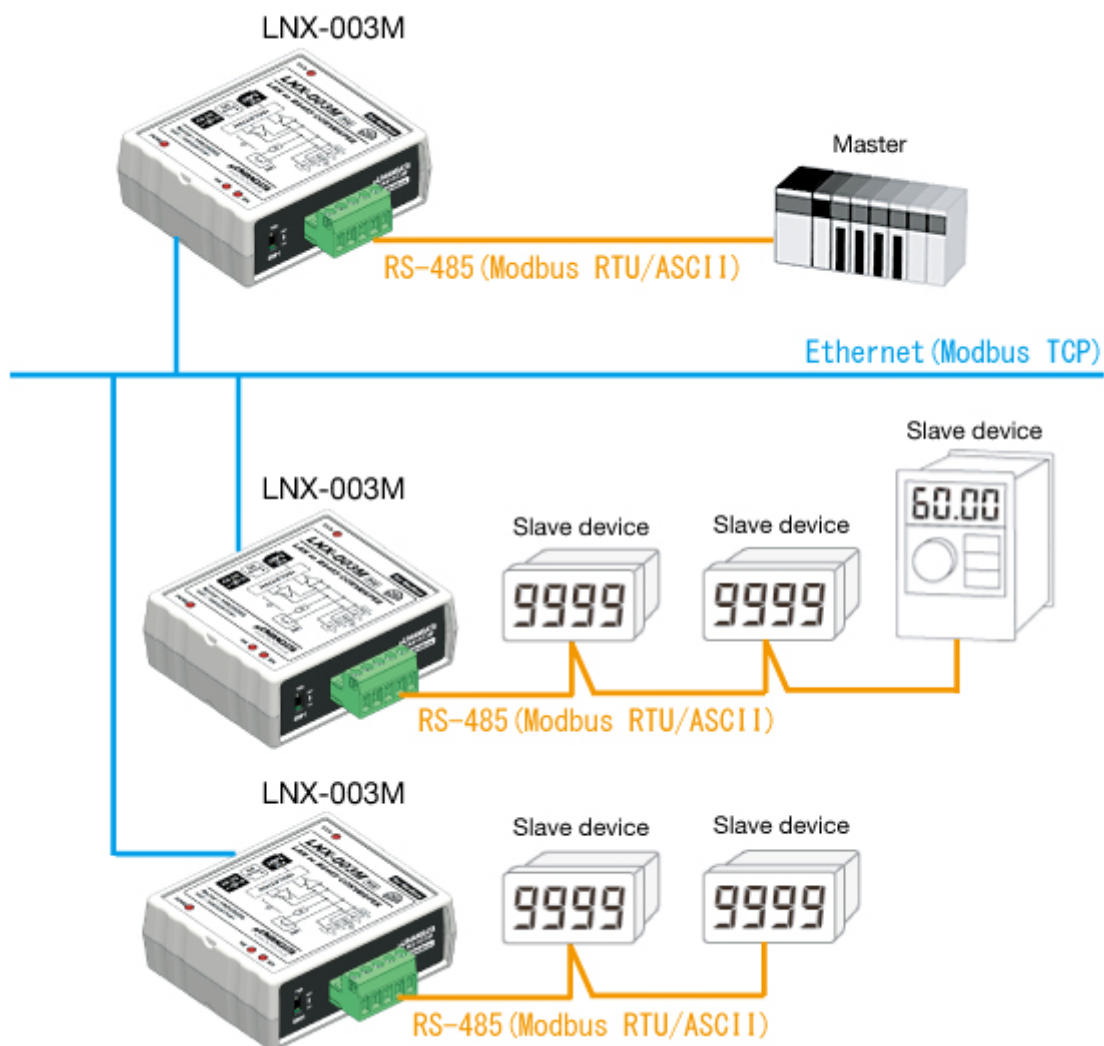

Direct communication between the two LNX-003Me without PCs offers you to connect separated a RS-485 networks. By using cross cable, one to one connection is also available.

\* Please use a cross cable to connect LNX-003Me without using a hub.  
(LNX-003Me does not have a function for AutoMDI/MDI-X.)

## 7. Setting Tool

Setting tool supports data saving and reading using microSD card. This tool does not require installation.

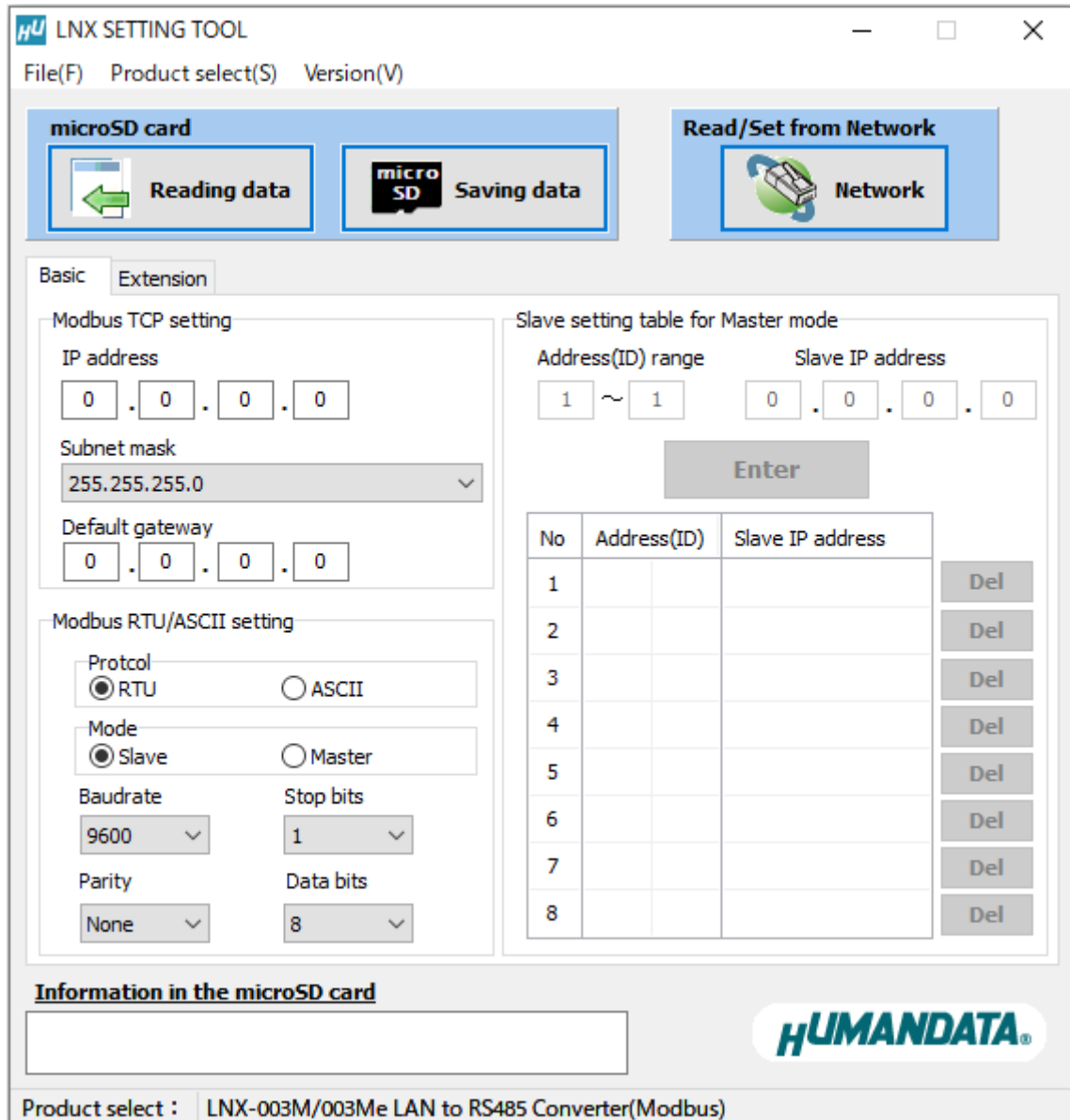

### 7.1. Access Flow of microSD card

Access to the microSD card is done immediately after power input. When TX/RX LED is turn on, do not detach the microSD card. Please detach it after confirming TX/RX LED is turn off.

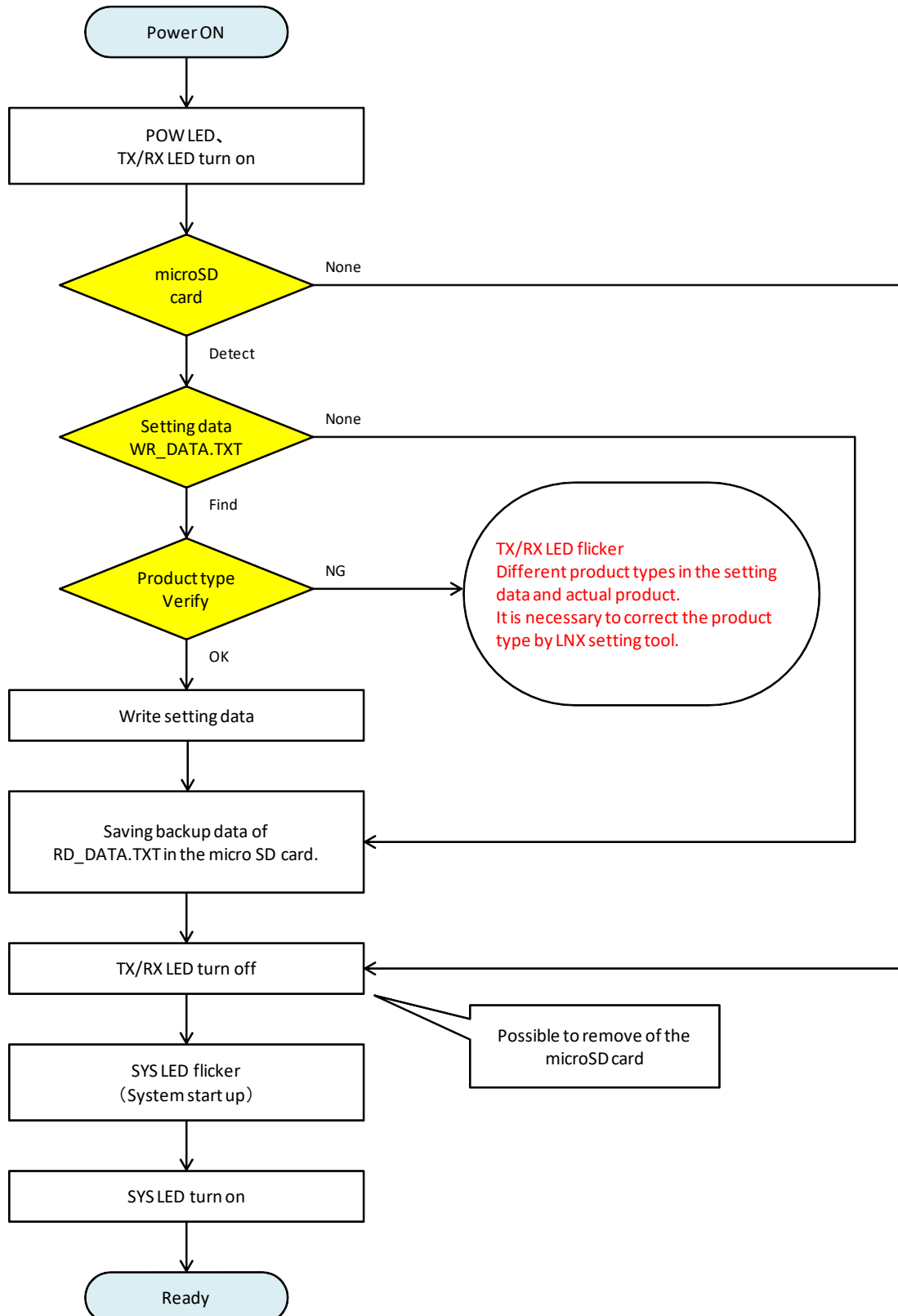

## 7.2. Function

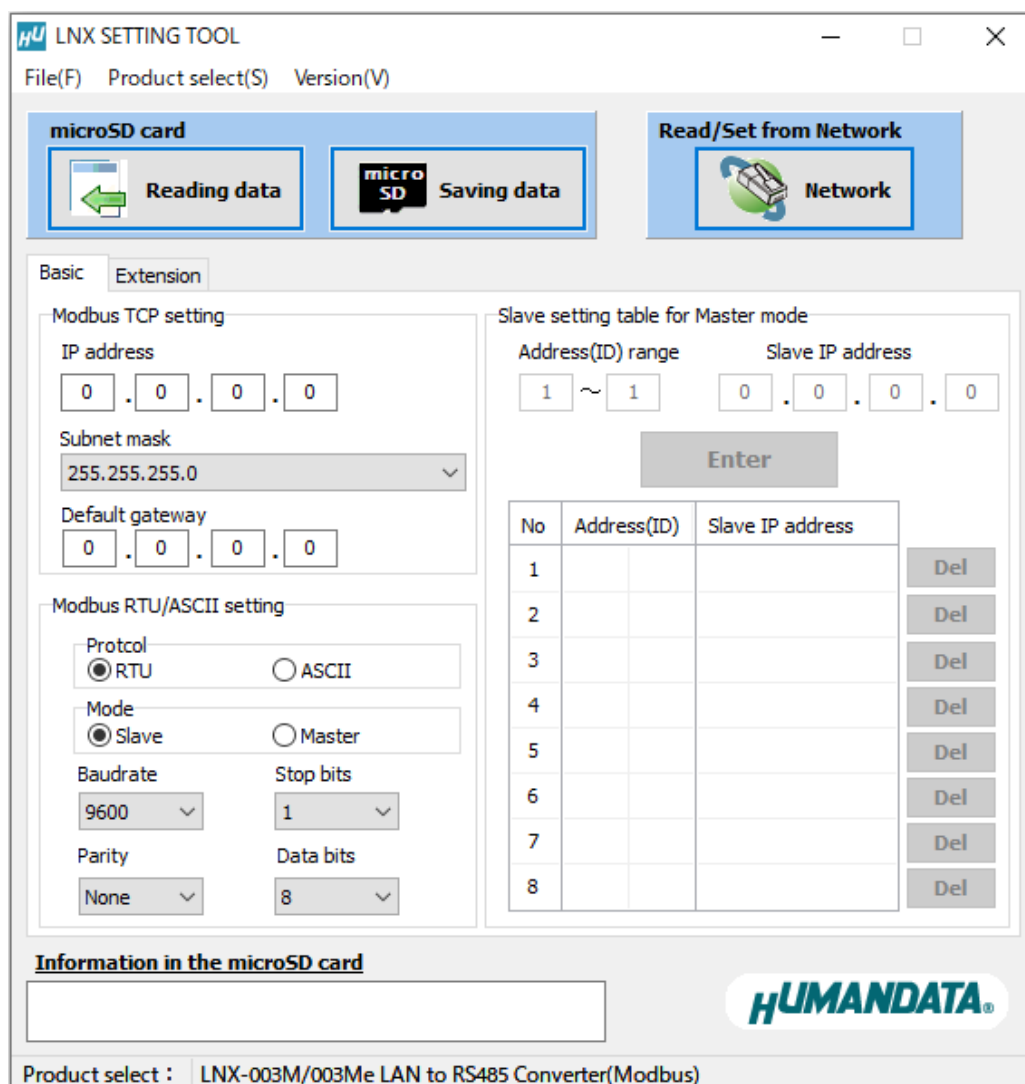

Item	Contents
File(F) -> Reading data(R)	Read setting data (RD_DATA.txt) from microSD card. MAC address and firmware version is showed in the column “Information in the microSD card”.
File(F) -> Saving data(S)	Save setting data (WR_DATA.txt) to microSD card.
File(F) -> Copy to clipboard(C)	Copy a display image to clipboard.
File(F) -> Exit(X)	Terminate the application.
Product select(S)	Display product select window. You can select language from Japanese or English.
Version(V)	Display version information window.



<b>Reading data</b>	Same function as "File (F)-> Reading data (R)"
<b>Saving data</b>	Same function as "File (F)-> Saving data (S)"
<b>Network</b>	Read or write setting data over the network. LNX product and PC must be connected to the same network segment.
<b>Information in the microSD card</b>	When the setting data (RD_DATA.TXT) is read from the microSD card, the MAC address and product firmware version are displayed.

[Basic Setting]

The screenshot shows the 'Basic' tab of the configuration interface. It is divided into two main sections: 'Modbus TCP setting' and 'Modbus RTU/ASCII setting'. The 'Modbus TCP setting' section includes fields for IP address (192.168.0.100), Subnet mask (255.255.255.0), and Default gateway (0.0.0.0). The 'Modbus RTU/ASCII setting' section includes radio buttons for Protocol (RTU selected) and Mode (Master selected), along with dropdown menus for Baudrate (9600), Stop bits (1), Parity (None), and Data bits (8). To the right, the 'Slave setting table for Master mode' is displayed, showing an 'Address(ID) range' of 130 ~ 133 and a 'Slave IP address' of 192.168.0.0. Below this is a table with columns 'No', 'Address(ID)', and 'Slave IP address', containing entries for addresses 1, 20, and 130, each with a 'Del' button. An 'Enter' button is also visible above the table.

Item	Contents
<b>IP address</b>	Assign IP address. The IP address must be set to a unique value in the network. The default value is 0.0.0.0 (auto setting).
<b>Subnet mask</b>	Set subnet mask
<b>Default gateway</b>	Set router IP address. When you use the product within the local network, please set to the default value, [0.0.0.0].
<b>Protocol</b>	Select Modbus protocol from RTU or ASCII.
<b>Mode</b>	Select mode from Slave or Master. When you select Master, Slave setting table in the right-side panel is valid.
<b>Baudrate</b>	Set baud rates from 300, 600, 1200, 2400, 4800, 9600, 19200, 38400, 57600 or 115200.

<b>Stop bits</b>	Select from 1 or 2 bit. The default setting is 1.
<b>Parity</b>	Select from Even, Odd or None. The default setting is none.
<b>Data bits</b>	Select from 7 or 8 bit. The default setting is 8.
<b>Address(ID) range</b>	Set range of Slave address (unit ID)
<b>Slave IP address</b>	Set IP address of slave side. Set the value of 4 <sup>th</sup> octet to 0, the value is set the same value of address ID. In the above example, When the Address ID is 130, Slave IP address is set to 192.168.0.130. Address ID is 131, Slave IP address is set to 192.168.0.131.
<b>Enter</b>	Resister to the list
<b>Del</b>	Delete the line

[Extension Setting]

Item	Contents
<b>Slave address (Fixed)</b>	When the mode is Slave, this setting is valid. If the unit ID of Modbus TCP is 0, please set this fixed value. When you set the fixed value, you can connect only one slave device. Normally set this value to 0.

<b>Modbus Serial Broadcasts</b>	<p>When this value is set to Disable and unit ID of Modbus TCP is 0, Modbus slave id is set to 1.</p> <p>When this value is set to Enable, the data is sent to according to the setting of unit ID of Modbus TCP.</p>
<b>Modbus TCP 0x0B/0x0A exception Responses</b>	<p>Select use Exception Responses or not.</p> <p>0x0B, TARGET DEVICE FAILED TO RESPOND, is software error</p> <p>0x0A, PATH UNAVAILABLE, is hardware error</p>
<b>Modbus/TCP Pipeline</b>	<p>When this value is set to Enable, request is buffered. Normally set this value to Enable.</p> <p>When this value is set to Disable, request is not buffered and old request is deleted. Only answer to the newest data is sent.</p>
<b>Modbus RTU timeout</b>	<p>Modbus RTU command needs to be start and end with a silent time defined with 3.5 characters. This value is set the silent time. When the value is set to 0, the timeout time is automatically calculated.</p> <p>When the value is from 10 to 645 msec, you can set the value at 5 msec interval. When the value is from 650 to 6950 msec, you can set the value at 50 msec interval.</p> <p>The default value is 50 msec, a normally safe value.</p>
<b>Message timeout</b>	<p>Set timeout time of answer from slave device connected by Modbus TCP or serial.</p> <p>When the value is from 200 to 1470 msec, you can set the value at 10 msec interval. When the value is from 1500 to 65000 msec, you can set the value at 500 msec interval.</p>
<b>RS485 transmission delay</b>	<p>Set this time when you need to delay the next transmission after receive the data from serial side.</p>

### 7.3. Write Setting Data

1. Open Setting Tool for LNX series (LNX SETTING TOOL Ver\*.\*)
2. Select “LNX-003M/003Me LAN to RS485 Converter(Modbus)”, and click “OK”.

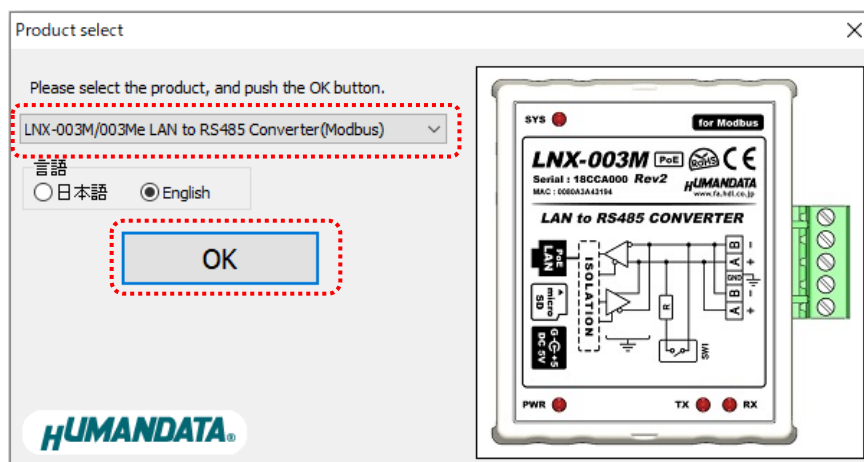

3. Enter the setting such as network or serial.
4. Insert a microSD card to PC (A USB adapter is included with the product)
5. Click “Save data”.

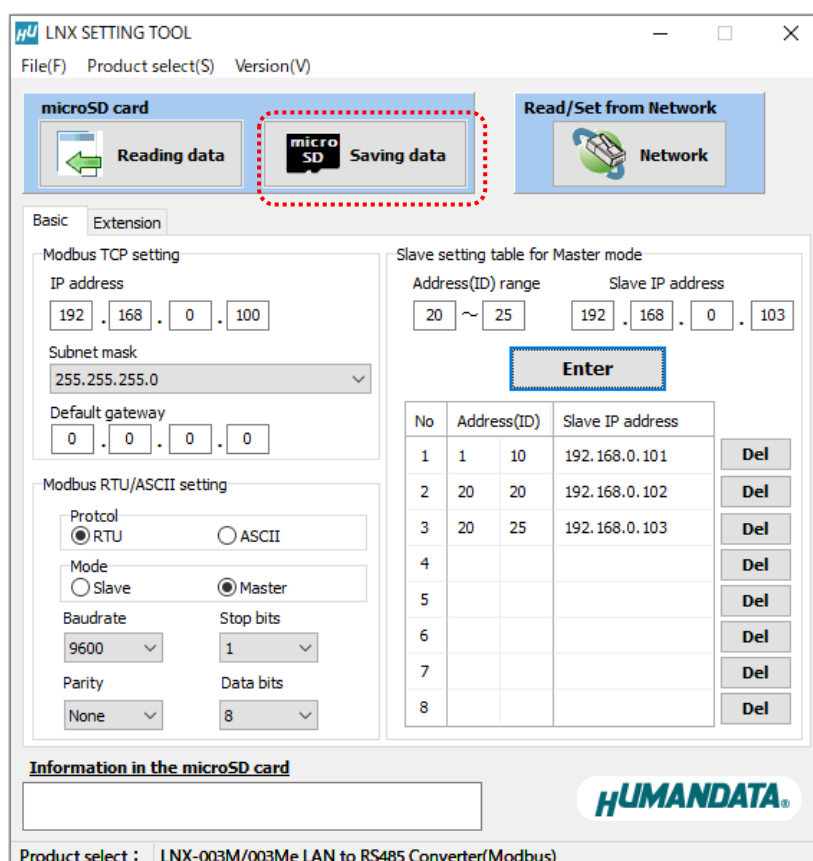

6. Click “OK” in the confirmation dialog.

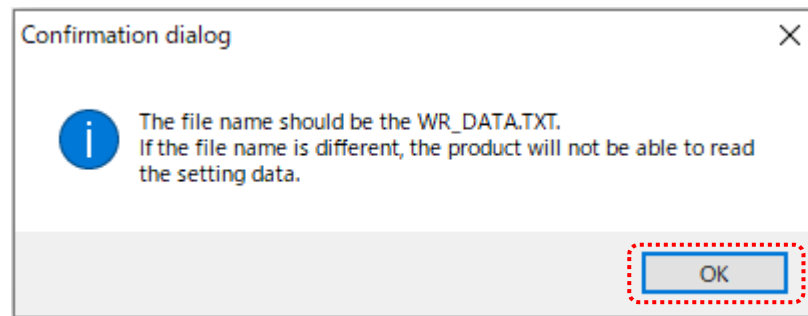

7. Specify the microSD card as saving destination. Please do not change the file name from “WR\_DATA.TXT”.
8. Remove the microSD card from PC and insert it to the product. Please confirm that the product power is turned off.
9. When the product is powered on, the setting data is configured to it automatically. After the data is stored in the product, microSD card is not needed any more. The start-up time can be shortened if the microSD card is removed from the product.  
Please be careful not to detach the microSD card before TX/RX LED is light off.

## 7.4. Read Setting Data

1. After confirming the power off, insert the microSD card to the product.
2. When the product is powered on, the setting data will be reserved to the microSD card automatically. The data file name is “RD\_DATA.TXT”.

Please be careful not to detach the microSD card before TX/RX LED is light off.

\* If there is the same file name in the microSD card, the data will be overwritten.

3. Insert a microSD card to PC (A USB adapter is included with the product)
4. Start the setting tool and click “Reading data”.

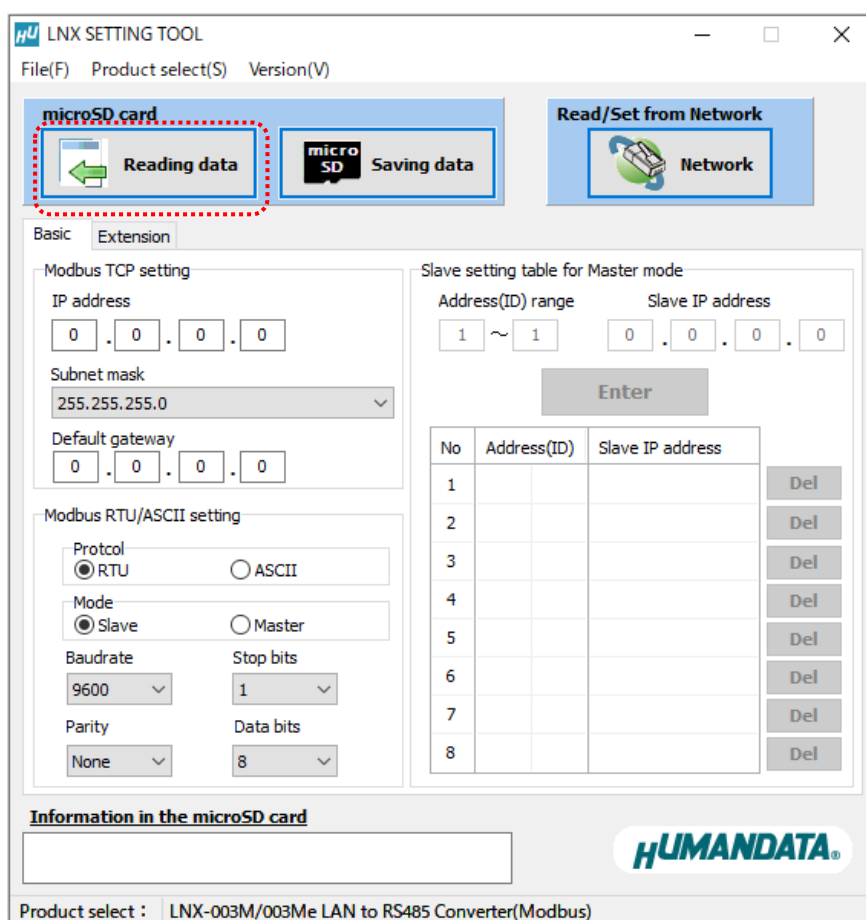

- Click “OK” in the confirmation dialog.

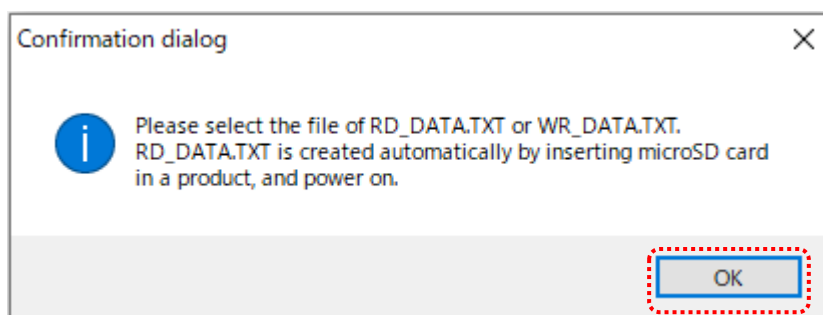

- Open the “RD\_DATA.TXT” in the microSD card.
- Setting data is loaded.

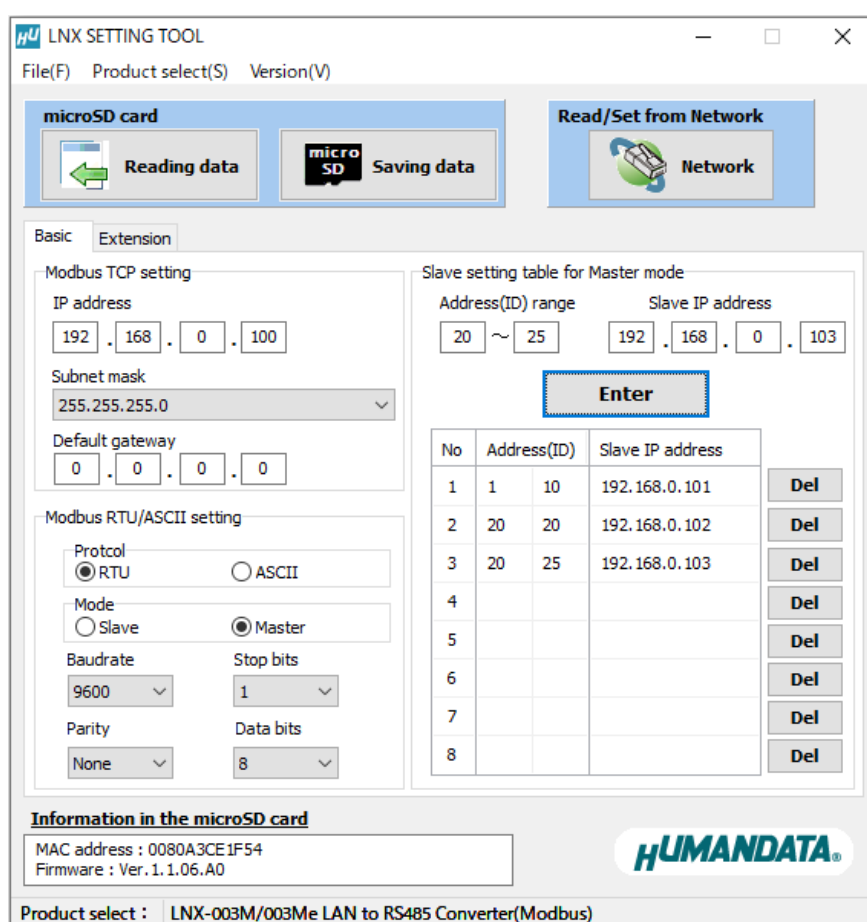

## 7.5. Write or Read setting data over the network

1. Enter the setting such as network or serial and click “Network”.

\* Please confirm that microSD card is not inserted in a product.

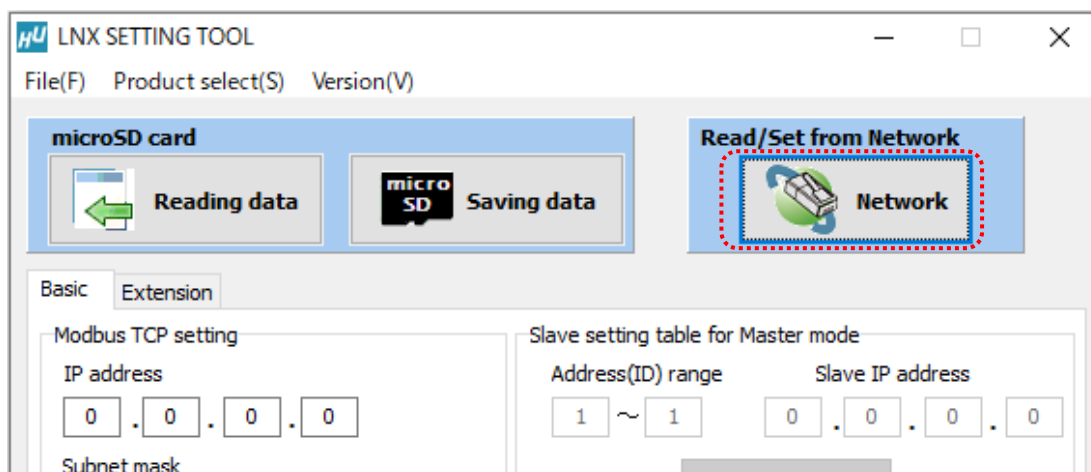

2. Enter an IP address manually or click “Search”. When some products are found, please select a number from a list.

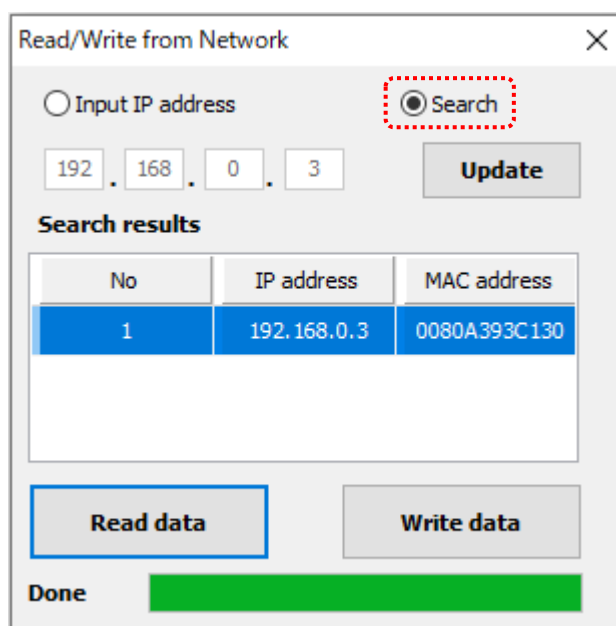

3. Click “Read data” or “Write data”

\* Even if some devices will be listed in the list and occur process time out. In this case, please change the PCs’ network setting to the same network segment as the product or using microSD card.



## 7.6. Setting Example

[LNX-003Me Slave Mode, Modbus RTU]

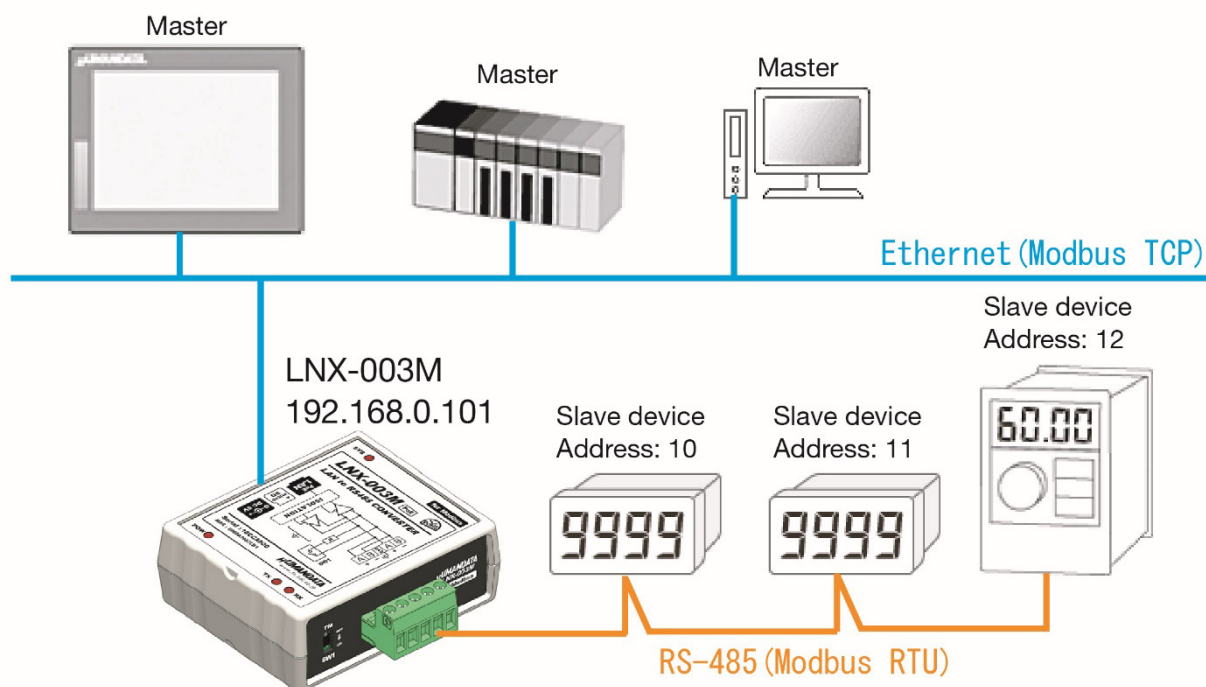

LNX-003Me setting

Basic    Extension

**Modbus TCP setting**

IP address  
 .  .  .

Subnet mask

Default gateway  
 .  .  .

**Modbus RTU/ASCII setting**

Protocol  
 RTU     ASCII

Mode  
 Slave     Master

Baudrate

Stop bits

Parity

Data bits

**Slave setting table for Master mode**

Address(ID) range    Slave IP address

~      .  .  .

No	Address(ID)	Slave IP address	
1			Del
2			Del
3			Del
4			Del
5			Del
6			Del
7			Del
8			Del

All values except in a red frame are default value.

[LNX-003Me Master Mode, Modbus RTU]

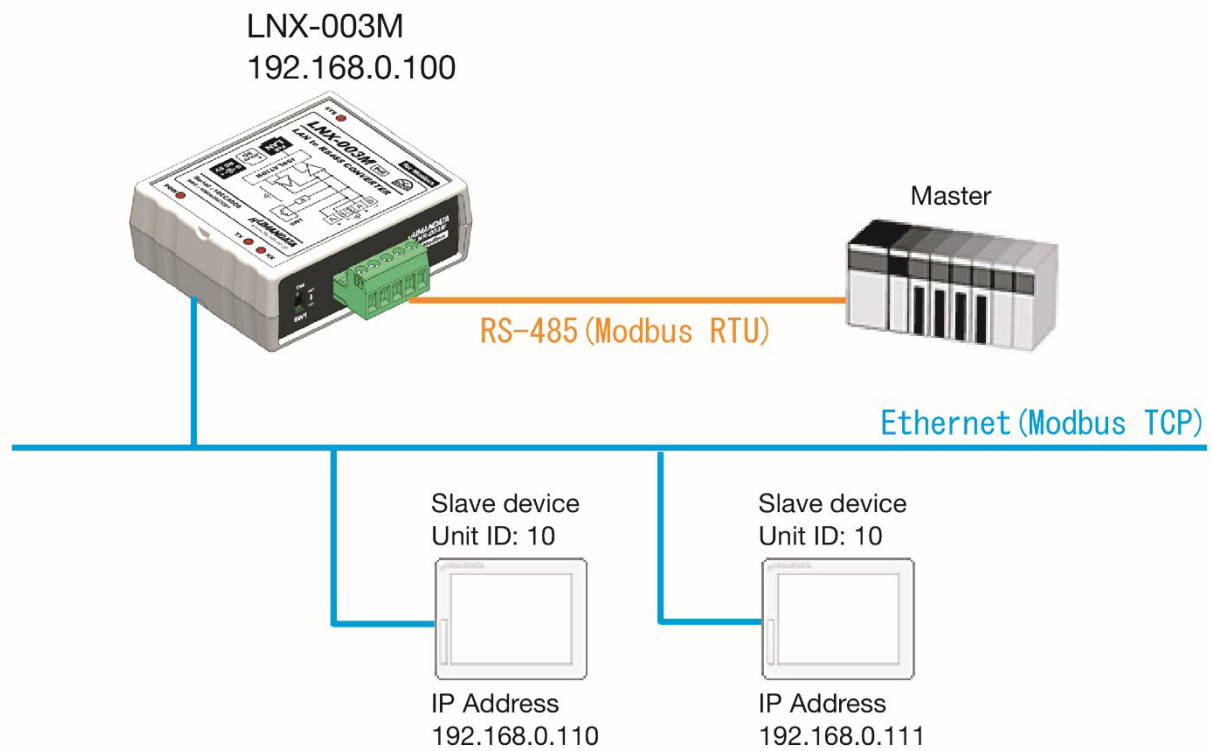

LNX-003Me setting

Basic Extension

Modbus TCP setting

IP address: 192 . 168 . 0 . 100

Subnet mask: 255.255.255.0

Default gateway: 0 . 0 . 0 . 0

Modbus RTU/ASCII setting

Protocol:  RTU  ASCII

Mode:  Slave  Master

Baudrate: 9600 Stop bits: 1

Parity: None Data bits: 8

Slave setting table for Master mode

Address(ID) range: 1 ~ 1 Slave IP address: 0 . 0 . 0 . 0

Enter

No	Address(ID)	Slave IP address	
1	10	10	192.168.0.110 Del
2	11	11	192.168.0.111 Del
3			Del
4			Del
5			Del
6			Del
7			Del
8			Del

All values except in a red frame are default value.

[Tunneling mode between each LNX-003Me, Modbus RTU]

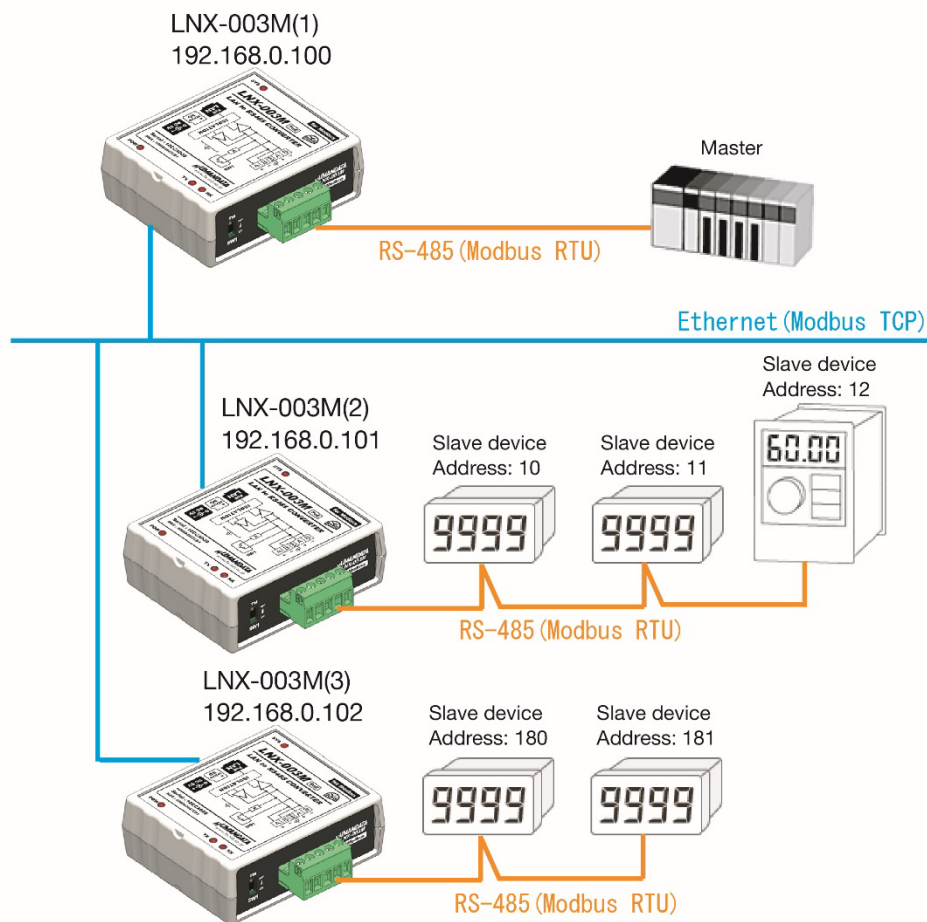

LNX-003Me (1) setting

Basic Extension

Modbus TCP setting

IP address: 192 . 168 . 0 . 100

Subnet mask: 255.255.255.0

Default gateway: 0 . 0 . 0 . 0

Modbus RTU/ASCII setting

Protocol:  RTU  ASCII

Mode:  Slave  Master

Baudrate: 9600 Stop bits: 1

Parity: None Data bits: 8

Slave setting table for Master mode

Address(ID) range: 1 ~ 1 Slave IP address: 0 . 0 . 0 . 0

Enter

No	Address(ID)	Slave IP address		
1	10	12	192.168.0.101	Del
2	180	181	192.168.0.102	Del
3				Del
4				Del
5				Del
6				Del
7				Del
8				Del

### LNX-003Me (2) setting

Basic
Extension

**Modbus TCP setting**

IP address  
 .  .  .

Subnet mask

Default gateway  
 .  .  .

**Slave setting table for Master mode**

Address(ID) range      Slave IP address

~        .  .  .

No	Address(ID)	Slave IP address	
1			<input style="border: 1px solid #ccc; padding: 2px 5px;" type="button" value="Del"/>
2			<input style="border: 1px solid #ccc; padding: 2px 5px;" type="button" value="Del"/>
3			<input style="border: 1px solid #ccc; padding: 2px 5px;" type="button" value="Del"/>
4			<input style="border: 1px solid #ccc; padding: 2px 5px;" type="button" value="Del"/>
5			<input style="border: 1px solid #ccc; padding: 2px 5px;" type="button" value="Del"/>
6			<input style="border: 1px solid #ccc; padding: 2px 5px;" type="button" value="Del"/>
7			<input style="border: 1px solid #ccc; padding: 2px 5px;" type="button" value="Del"/>
8			<input style="border: 1px solid #ccc; padding: 2px 5px;" type="button" value="Del"/>

**Modbus RTU/ASCII setting**

Protocol  
 RTU       ASCII

Mode  
 Slave       Master

Baudrate      Stop bits  
     

Parity      Data bits

All values except in a red frame are default value.

### LNX-003Me (3) setting

Basic
Extension

**Modbus TCP setting**

IP address  
 .  .  .

Subnet mask

Default gateway  
 .  .  .

**Slave setting table for Master mode**

Address(ID) range      Slave IP address

~        .  .  .

No	Address(ID)	Slave IP address	
1			<input style="border: 1px solid #ccc; padding: 2px 5px;" type="button" value="Del"/>
2			<input style="border: 1px solid #ccc; padding: 2px 5px;" type="button" value="Del"/>
3			<input style="border: 1px solid #ccc; padding: 2px 5px;" type="button" value="Del"/>
4			<input style="border: 1px solid #ccc; padding: 2px 5px;" type="button" value="Del"/>
5			<input style="border: 1px solid #ccc; padding: 2px 5px;" type="button" value="Del"/>
6			<input style="border: 1px solid #ccc; padding: 2px 5px;" type="button" value="Del"/>
7			<input style="border: 1px solid #ccc; padding: 2px 5px;" type="button" value="Del"/>
8			<input style="border: 1px solid #ccc; padding: 2px 5px;" type="button" value="Del"/>

**Modbus RTU/ASCII setting**

Protocol  
 RTU       ASCII

Mode  
 Slave       Master

Baudrate      Stop bits  
     

Parity      Data bits

All values except in a red frame are default value.

LNX-003Me (Ver.1.1)

25

## 8. Factory Setting (default value)

[Basic]

No	Item	Factory setting (default)	Memo
1	IP Address	0.0.0.0	
2	Subnet Mask	255.255.255.0	
3	Default Gateway	0.0.0.0	
4	Protocol	RTU	
5	Mode	Slave	
6	Baud rate	9600	
7	Stop Bits	1	
8	Parity	None	
9	Data Bits	8	
10	No1 Address (ID) range	-	
11	No1 Slave IP address	-	
12	No2 Address (ID) range	-	
13	No2 Slave IP address	-	
14	No3 Address (ID) range	-	
15	No3 Slave IP address	-	
16	No4 Address (ID) range	-	
17	No4 Slave IP address	-	
18	No5 Address (ID) range	-	
19	No5 Slave IP address	-	
20	No6 Address (ID) range	-	
21	No6 Slave IP address	-	
22	No7 Address (ID) range	-	
23	No7 Slave IP address	-	
24	No8 Address (ID) range	-	
25	No8 Slave IP address	-	

[Extension]

No	Item	Factory setting (default)	Memo
1	Slave address (Fixed)	0	
2	Modbus Serial Broadcasts	Disable	
3	Modbus TCP 0x0B/0x0A exception Responses	Yes	
4	Modbus/TCP Pipeline	Enable	
5	Modbus RTU timeout	50	
6	Message timeout	5000	
7	RS485 transmission delay	0	

## 9. Virtual COM Port

You can use the software that maps Virtual COM ports on a PC platform. It redirects application data destined to an attached device via the PC's local serial (COM) port. Rather than going out the local port, the data is transmitted across the Ethernet network using TCP/IP. LNX-003Me attached to the network receives the data and transfers it from its own serial port to the attached equipment. Please refer to the "LNX series virtual COM port User's Manual" that are stored on the product supplied CD for details.

## 10. Additional Documentation and User Support

The following documents and other supports are available at

<https://www.hdl.co.jp/en/faspc/LNX/lrx-003M/>

- LNX SETTING TOOL
- Outline drawing  
... and more.

## 11. Attachment Documentations

- Outline drawing of the LNX-003Me
- Outline drawing of the AC Adapter

## 12. Warranty and compensation

Please refer to the following URL for the warranty.

<https://www.fa.hdl.co.jp/en/fa-warranty.html>

---

# **RS-485 LAN Converter for Modbus [Economy type]**

LNX-003Me Rev2

User's Manual

Ver. 1.1 .....Nov 7, 2024

---

## **HuMANDATA LTD.**

Address: 1-2-10-2F, Nakahozumi, Ibaraki  
Osaka, Japan  
ZIP 567-0034

Tel: 81-72-620-2002 (Japanese)

Fax: 81-72-620-2003 (Japanese/English)

URL: <https://www.fa.hdl.co.jp> (Japan)

<https://www.fa.hdl.co.jp/en/> (Global)

---