

RS-232C LAN Converter
[Economy type]



LNX-002e (Rev3)

User's Manual

Ver. 3.1

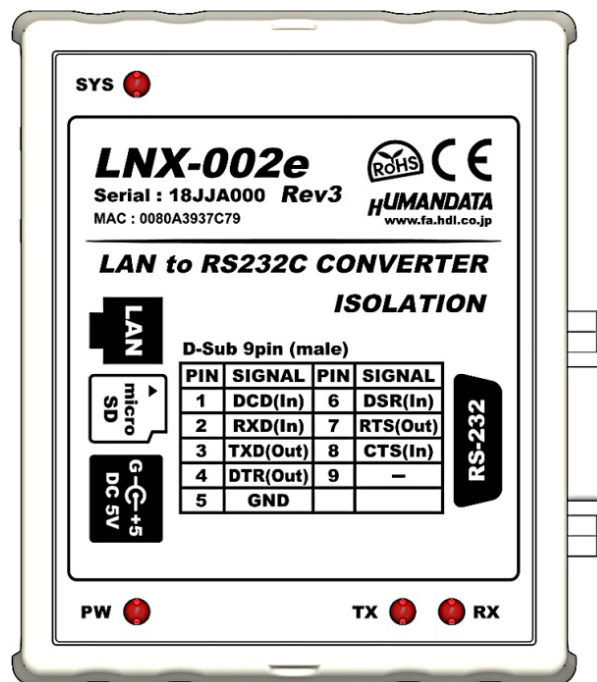



Table of Contents

● Precautions	1
● Revision History	2
● Introduction	2
1. Product Configuration	2
2. Product Summary	2
3. Part Names and Functions	3
4. Specifications	5
4.1. Product Specification	5
4.2. AC adapter(Japan's specifications)	6
4.3. Optional Accessories	7
4.4. Power Supply	7
5. RS232C Pin Assignment	8
6. Connection examples	9
7. Setting Tool	10
7.1. Access Flow of microSD card	11
7.2. Write Setting Data	12
7.3. Read Setting Data	13
7.4. Write or Read setting data over the network	15
7.5. Setting Example	16
8. Virtual COM Port	18
9. Additional Documentation and User Support	18
10. Warranty and compensation	18

● **Precautions**

 <p>Do Not</p>	1	This product uses ordinary off-the-shelf electronic components, and is therefore inappropriate for use in applications that require special quality or reliability and are expected to protect human lives or prevent accidents, such as safety mechanisms in fields including space, aeronautics, medicine, and nuclear power.
	2	Do not be used underwater or in high-humidity environments.
	3	Do not be used in the presence of corrosive gases, combustible gases, or other flammable gases.
	4	Do not turn on power when circuit board surface is in contact with other metal.
	5	Do not apply voltage higher than rated voltage.
 <p>Attention</p>	6	This manual may be revised in the future without notice owing to improvements.
	7	All efforts have been made to produce the best manual possible, but if users notice an error or other problem, we ask that they notify us.
	8	Item 7 notwithstanding, HuMANDATA cannot be held liable for the consequences arising from use of this product.
	9	HuMANDATA cannot be held liable for consequences arising from using this product in a way different from the uses described herein, or from uses not shown herein.
	10	This manual, circuit diagrams, sample circuits, and other content may not be copied, reproduced, or distributed without permission.
	11	If the product emits smoke, catches fire, or becomes unusually hot, cut the power immediately.
	12	Do not install the control cables or communication cables together with the main circuit lines or power cables. In such an environment, it may result in malfunction due to noise.
	13	Be careful of static electricity.

● Revision History

Date	Revision	Description
Feb. 13, 2018	v3.0	Upgrade product version to Rev 3.
Nov. 7, 2024	v3.1	Correct: typo

● Introduction

Thank you for purchasing our product of RS-232C LAN Converter [Economy type] LNX-002e.

LNX-002e is a LAN converter which makes it possible to use a RS-232C device via Ethernet local area network. LNX-002e is an economy model of LNX-002 from which only PoE function is removed.

1. Product Configuration

The following lists the product configuration of the LNX-002e.

RS-232C LAN Converter [Economy type] (LNX-002e)	1
microSD card with USB adapter	1
AC adapter (DC5V)	1
Driver & Application CD	1

2. Product Summary

LNX-002e is a LAN converter which makes it possible to use a RS-232C device via Ethernet local area network.

Tunneling mode is available with a LNX-001 (USB to LAN converter) or one more LNX-002e. By using TCP/UDP or Telnet, direct control from PC is also available.

LNX-002e is powered by the AC adapter.

Network setting can be saved to and restored from a microSD card. Restoring the setting information from a microSD card is very convenient when replacing LNX-002e.

3. Part Names and Functions

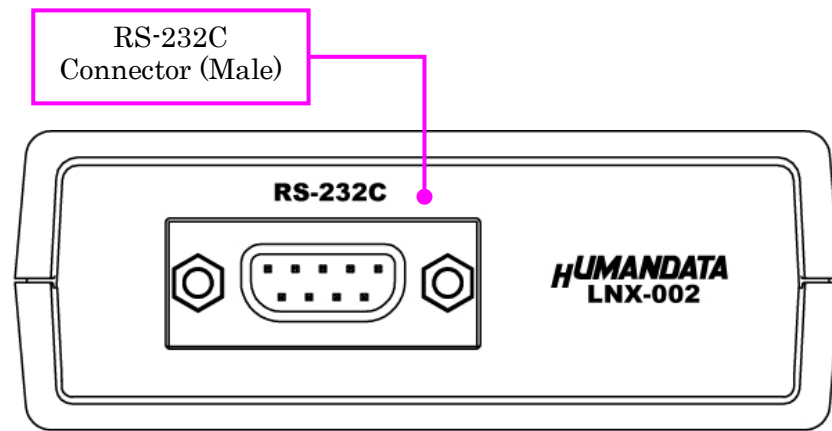

RS-232C Side

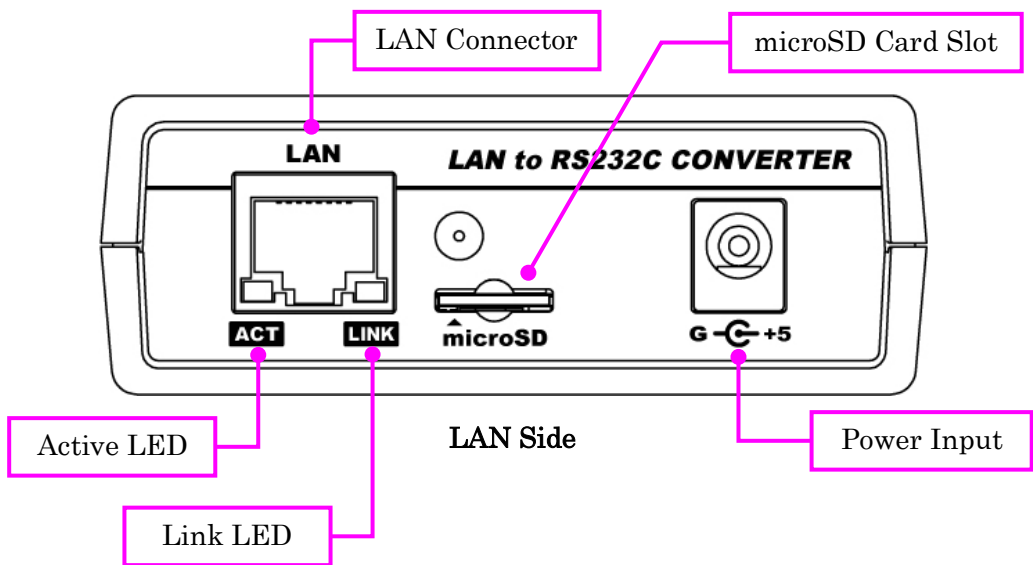

LAN Side

LEDs

	Name(color)	Function
ACT	Active LED (green)	Turn on during network port communication.
LINK	Link LED (yellow)	Turn on when LNX-002e is powered and LAN cable is connected normally.

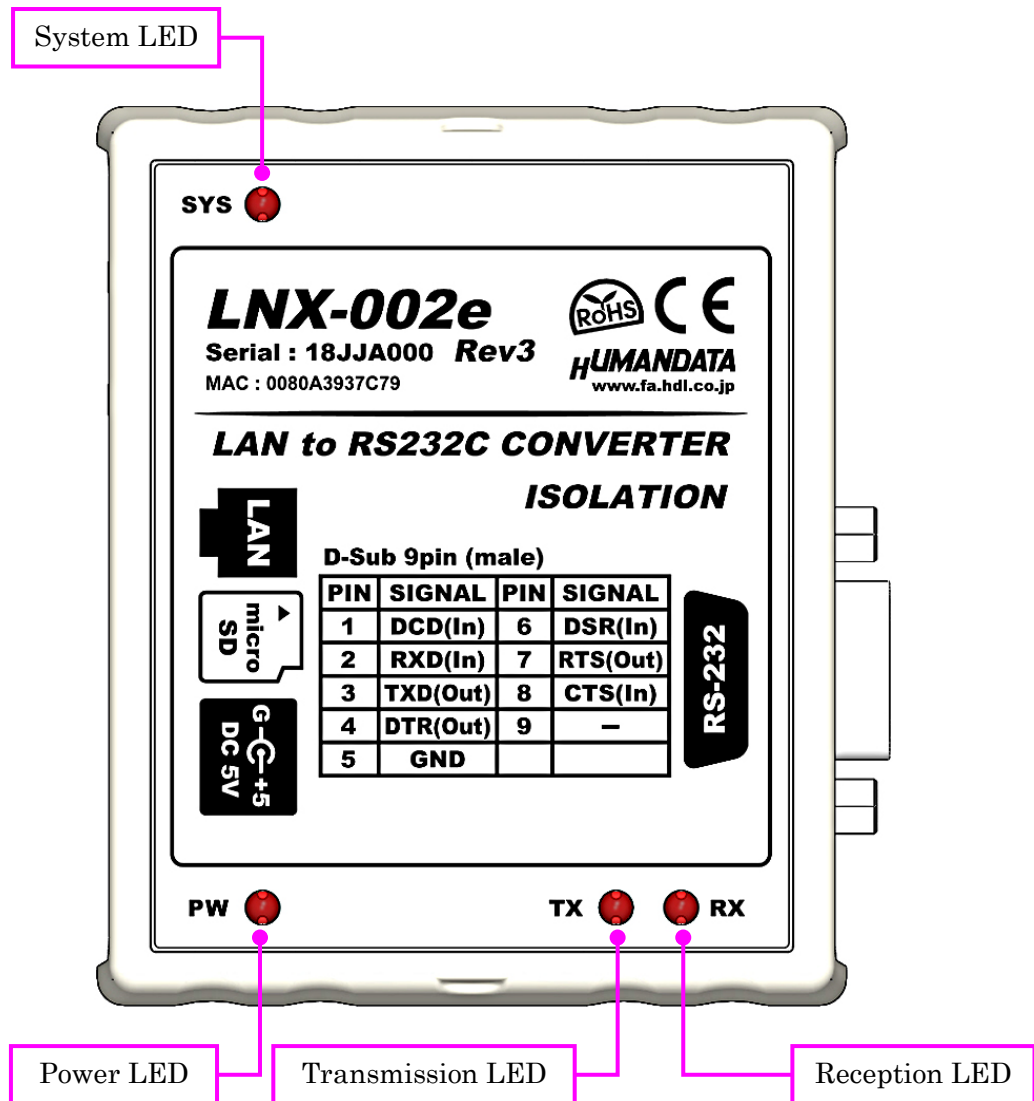

TOP Side

LEDs

	Name (color)	Function
SYS	System LED (red)	Blink few seconds during reading process. Turn on when system is ready.
PW	Power LED (red)	Turn on when the power is supplied to the LNX-002e.
TX	Transmission LED (red)	Turn on when data are transmitted to RS-232C side.
RX	Reception LED (red)	Turn on when data are received from RS-232C side.

4. Specifications

4.1. Product Specification

Item	Description	Remarks
Model	LNX-002e	
Power	DC 5 [V] Supplied by AC adapter	
Current Consumption	Less than 350mA	
Network Interface	IEEE802.3 (10Base-T) IEEE802.3u (100Base-TX) half-duplex / full-duplex (auto detected)	
LAN Connector	RJ45	ESD protection $\pm 11KV$ isolation over 1500Vrms
Protocol	TCP / UDP / Telnet	
Interface	RS-232C	ESD protection $\pm 15KV$
Connector	D-Sub 9pin Male	#4-40 UNC
Setting Memory Card	microSD card	SPI mode
Baud Rate	300, 600, 1200, 2400, 4800, 9600, 19200, 38400, 57600, 115200, 230400, 460800, 921600bps	
Data Bits	7 or 8 bits	
Stop Bits	1 or 2 bits	
Parity	Even, Odd, No parity	
LED	PW: Power LED RX: Reception LED TX: Transmission LED SYS: System LED LINK (RJ45 Connector): LINK Status ACT (RJ45 Connector): ACT Status	
Operating Ambient Temperature	-10 to 55 [°C] (14 to 131 [°F])	No condensation permitted. Except AC adapter
Operating Ambient Humidity	30 to 85 % RH	
Storage Ambient Temperature	-20 to 60 [°C] (-4 to 140 [°F])	
Storage Ambient Humidity	30 to 85 % RH	

Item	Description	Remarks
Weight	approx. 120 [g]	Only main body
Dimensions	69 x 82.5 x 30 [mm] 2.717" x 3.248" x 1.181"	Without projections
RoHS Compliance	YES	
Applicable standards	CE	

- * There may be cases that these parts and specifications are changed.
- * Power saving functions (suspend, standby, sleep and others) are not supported.
- * Please use the microSD card that is included in the package.

4.2. AC adapter(Japan's specifications)

Item	Description	Remarks
Output	5VDC 2.0A	
Plug	2.1mm inner diameter	Positive Tip
Compatible DC Jack	2.1mm inner diameter	
Operating Ambient Temperature	0 to 40 [°C] (32 to 104 [°F])	No condensation permitted
Operating Ambient Humidity	30 to 85 % RH	
Storage Ambient Temperature	-20 to 80 [°C] (-4 to 176 [°F])	
Storage Ambient Humidity	10 to 95 % RH	
Wire Length	1.6m	
Weight	approx. 70 [g]	
Dimensions	46 x 34 x 25 [mm] 1.811" x 1.339" x 0.984"	Without projections

- * This AC adapter is attached for use mainly in Japan. If you use in the other countries, please check the specifications above and plug shape.
- * There may be cases that this part and specifications are changed.

[CE marking]

LNX-002e have applied the common standard for industrial environment EN61000-6-2 and EN61000-6-4.

--- Application of the standards ---

EMS: EN61000-6-2

- EN61000-4-2(2009) Electrostatic discharge requirements
- EN61000-4-3(2010) Radiated electromagnetic field requirements
- EN61000-4-4(2010) Electrical fast transient burst requirements
- EN61000-4-5(2006) Surge immunity test requirements
- EN61000-4-6(2009) Conducted radio frequency requirements

EMI: EN61000-6-4

- EN61000-6-4(2007)+A1(2011) Radiated Emissions
- EN61000-6-4(2007)+A1(2011) Conducted Emissions

4.3. Optional Accessories

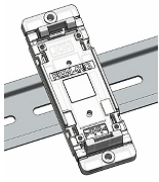
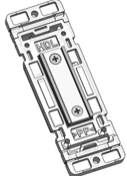
Model Name	Image	Description
PEN-003		Attachment with clamping screw JAN: 4937920800709
PEN-003-DIN		Attachment for 35mm DIN rail JAN: 4937920800716
PEN-003-MG		Attachment with neodymium magnet JAN: 4937920801201

4.4. Power Supply

LNX-002e requires an AC adapter for power supply. Please use the AC adapter which is included in the package.

5. RS232C Pin Assignment

Pin No	Name	Direction	Remarks
1	(DCD)	In	Data carrier detect
2	RXD	In	Receive data
3	TXD	Out	Transmit data
4	DTR	Out	Data terminal ready
5	GND	-	Signal ground
6	DSR	In	Data set ready
7	RTS	Out	Request to send
8	CTS	In	Clear to send
9	(RING)	In	Ring indicator
CASE	FG	-	Connect to GND

* DCD and RING signals are not supported.

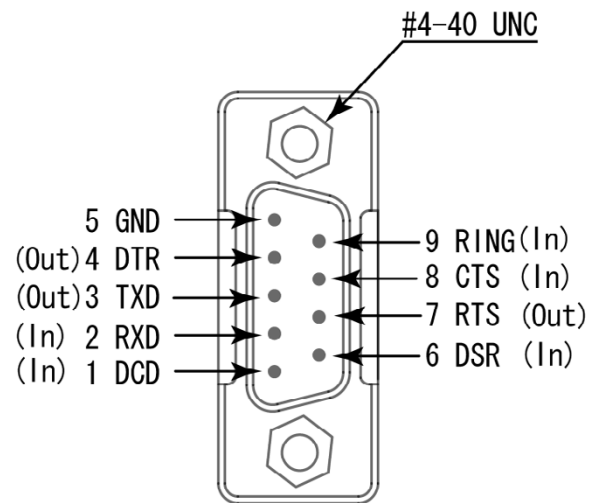

D-Sub 9pin Male

6. Connection examples

[Tunneling mode between two LNX-002e]

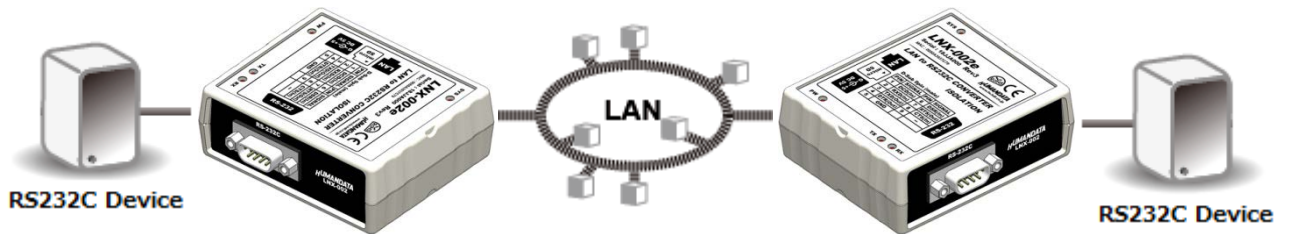

Direct communication between two LNX-002es without any PCs offers you a way to connect separated two RS-232C devices. By using a cross cable, one to one connection is also available.

[Tunneling mode between LNX-001 and LNX-002e]

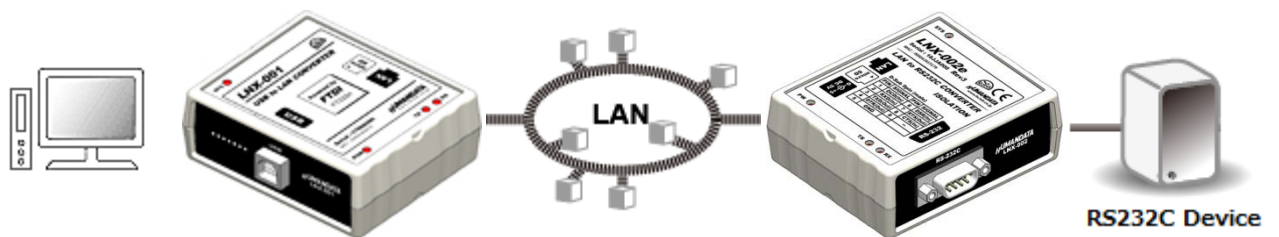

LNX-001 offers you to control as USB interface via a LAN. And is able to connect to a LNX-002e in tunneling mode, virtual COM port and D2XX-API by FTDI is available.

Technical knowledge about the network is not needed.

[LNX-002e single operation]



Communication with RS-232C devices via a local area network is available.

* Please use a cross cable to connect LNX-002e without using a hub.
(LNX-002e does not have a function for AutoMDI/MDI-X.)

7. Setting Tool

Setting tool supports to save and read network setting by a microSD card. This tool does not require installation.

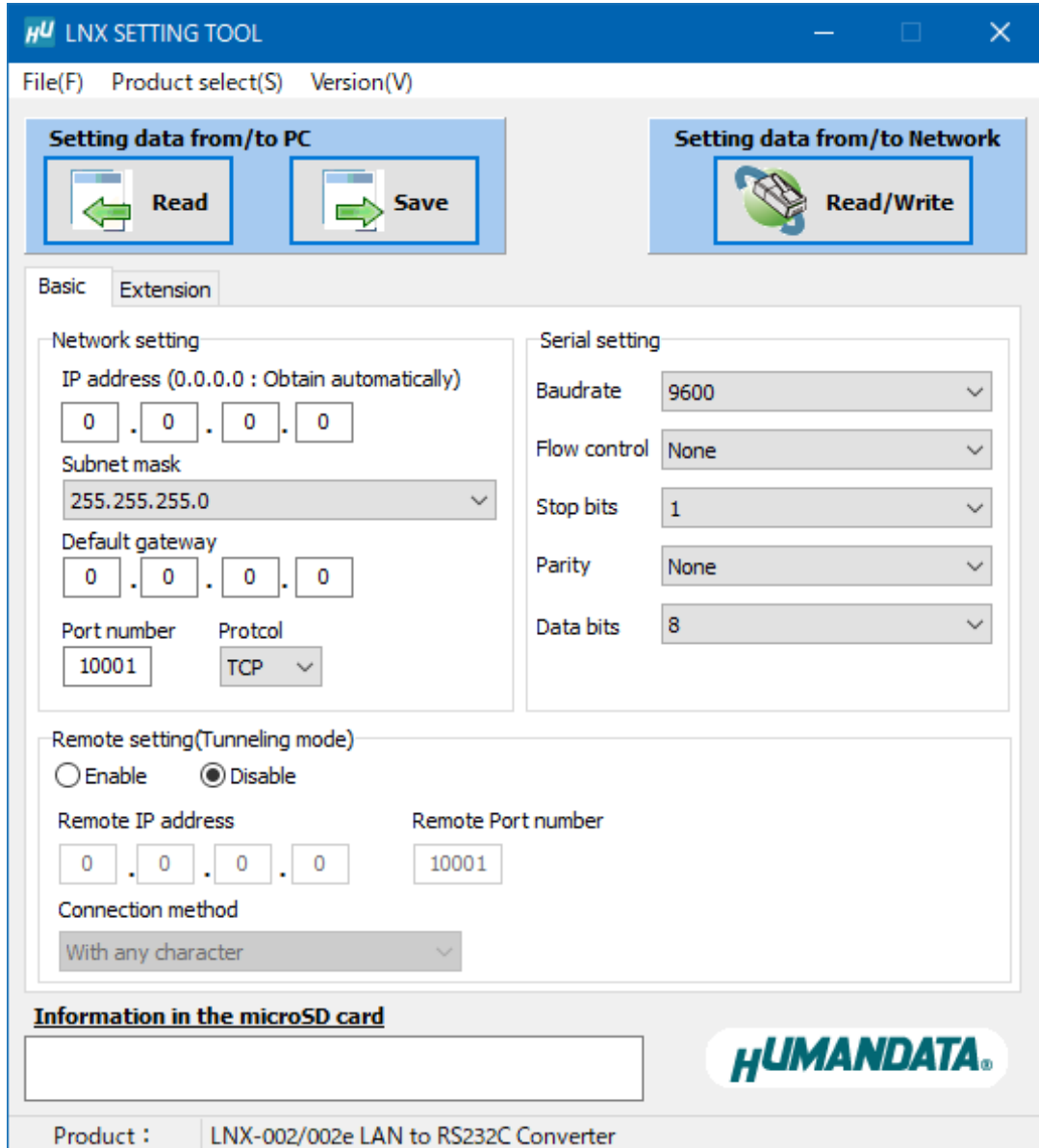

This is a screenshot from version 3.5

7.1. Access Flow of microSD card

Access to the microSD card is done immediately after power input. When TX/RX LEDs are lighting, do not detach the microSD card. You can detach it after confirming TX/RX LEDs are turned off.

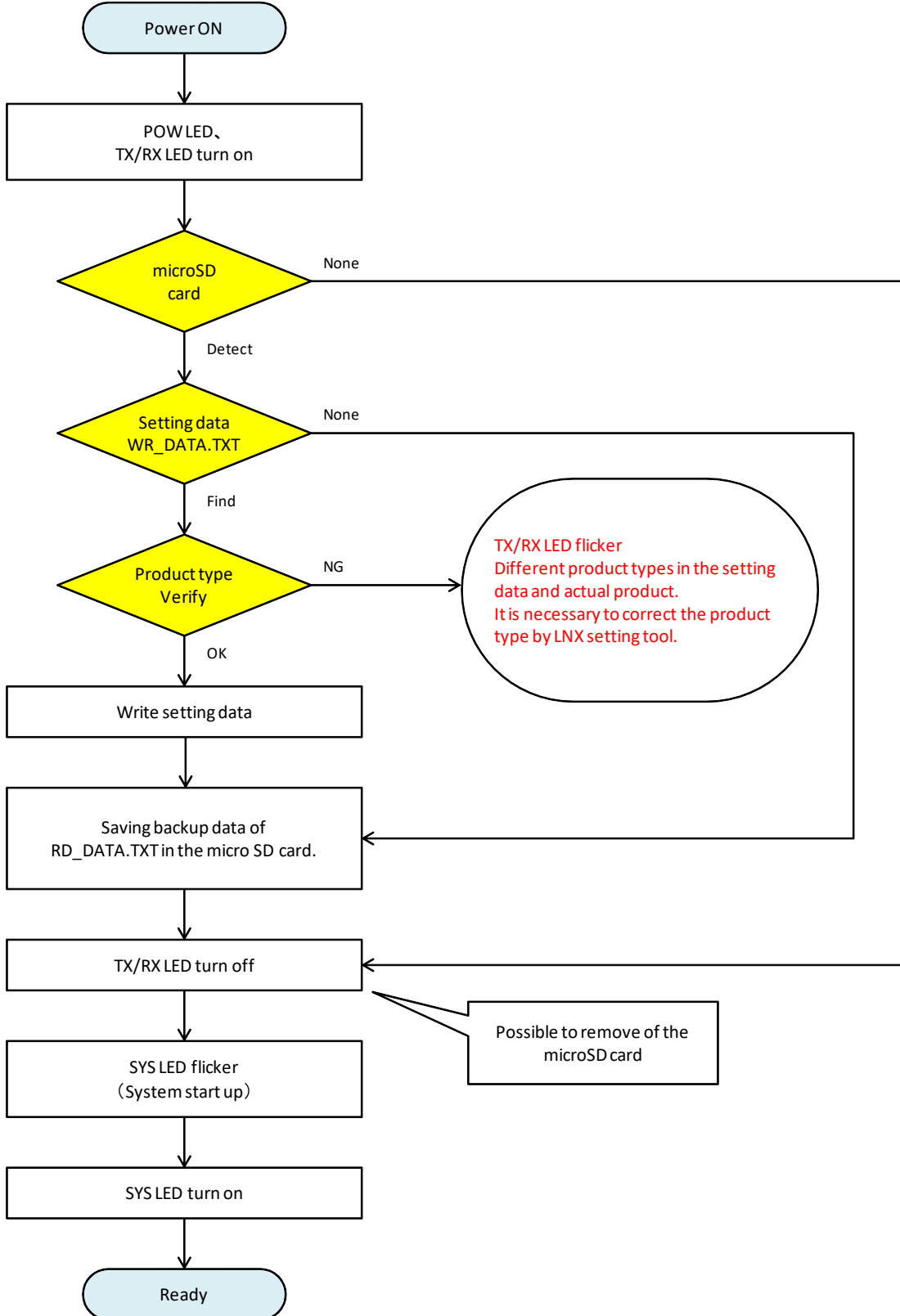

7.2. Write Setting Data

1. Open Setting Tool for LNX series (LNX SETTING TOOL Ver*. *).
2. Select “LNX-002/LNX-002e LAN to RS232C Converter”, and click “OK”.

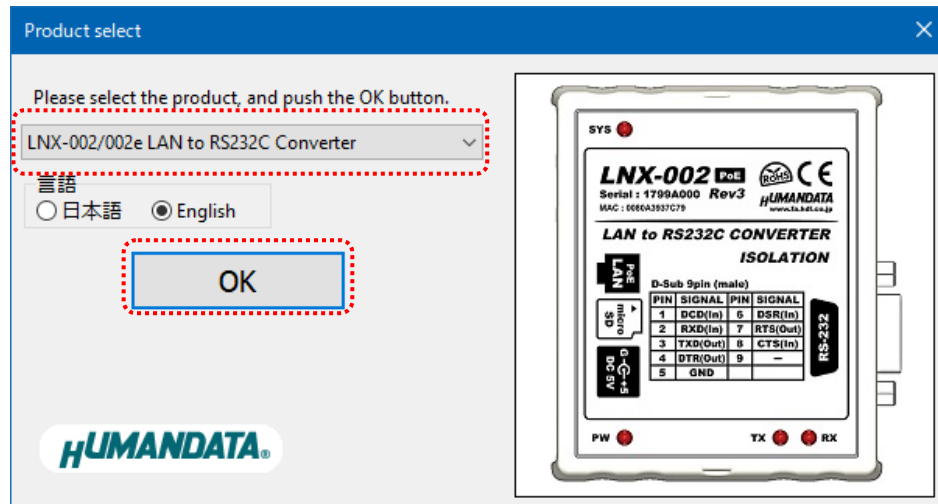

3. Enter the setting such as network or serial.
4. Insert a microSD card to PC (A USB adapter is included with the product)
5. Click “Saving data”.

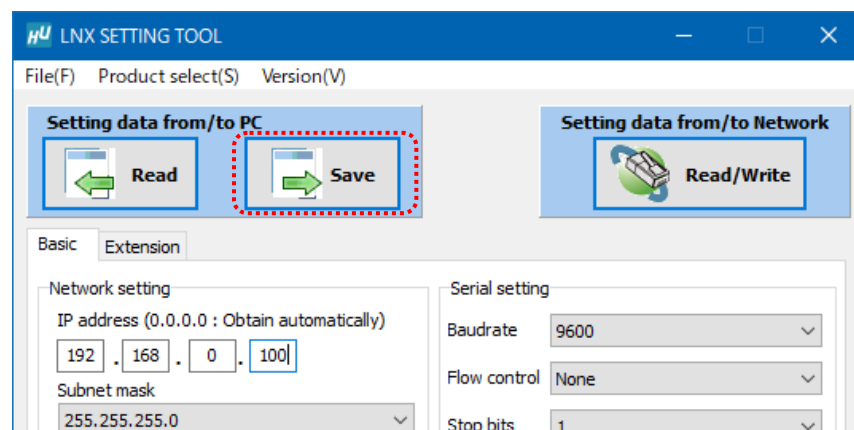

6. Click “OK” in the confirmation dialog.

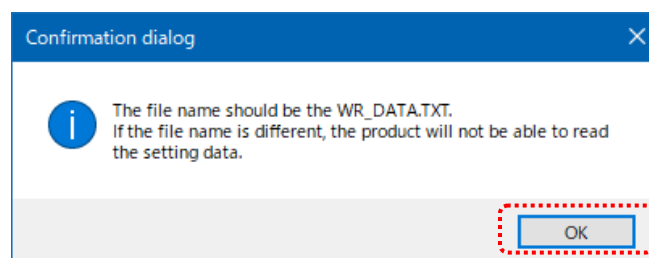

7. Specify the microSD card as saving destination. Please do not change the file name from “WR_DATA.TXT”.
8. Remove the microSD card from PC and insert it to the product. Please confirm that the product power is turned off.
9. When the product is powered on, the setting data is configured to the product automatically. After the data is stored in the product, microSD card is not needed any more. The start-up time can be shortened if the microSD card is removed from the product.
Please be careful not to detach the microSD card before TX/RX LED is turned off.

7.3. Read Setting Data

1. After confirming the power is off, insert the microSD card to the product.
2. When the product is powered on, the setting data will be reserved to the microSD card automatically. The data file name is “RD_DATA.TXT”.
Please be careful not to detach the microSD card before TX/RX LED is turned off.
* If there is the same file name in the microSD card, the data will be overwritten.
3. Insert a microSD card to PC (A USB adapter is included with the product)
4. Start the setting tool and click “Reading data”.

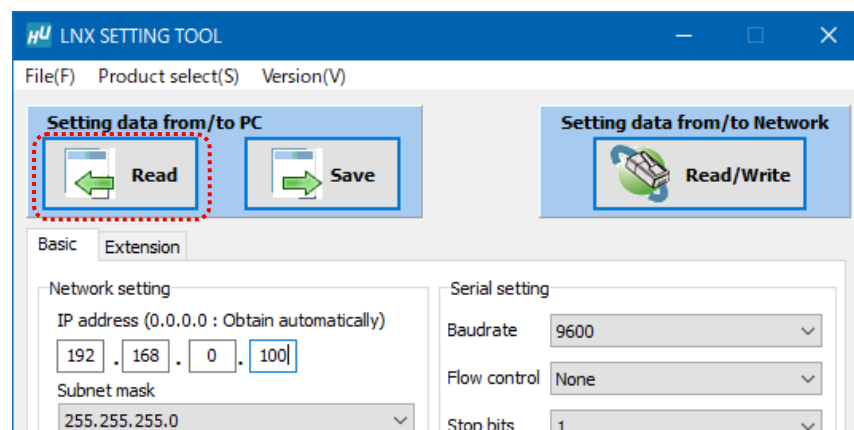

- Click “OK” in the confirmation dialog.

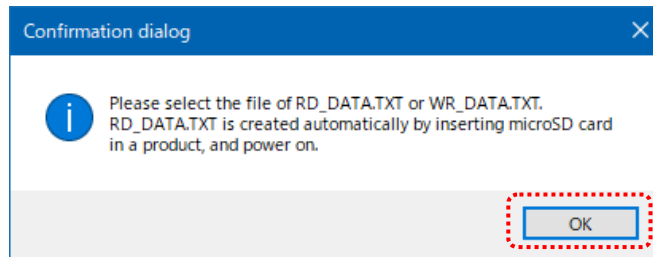

- Open the “RD_DATA.TXT” in the microSD card.
- Setting data is loaded.

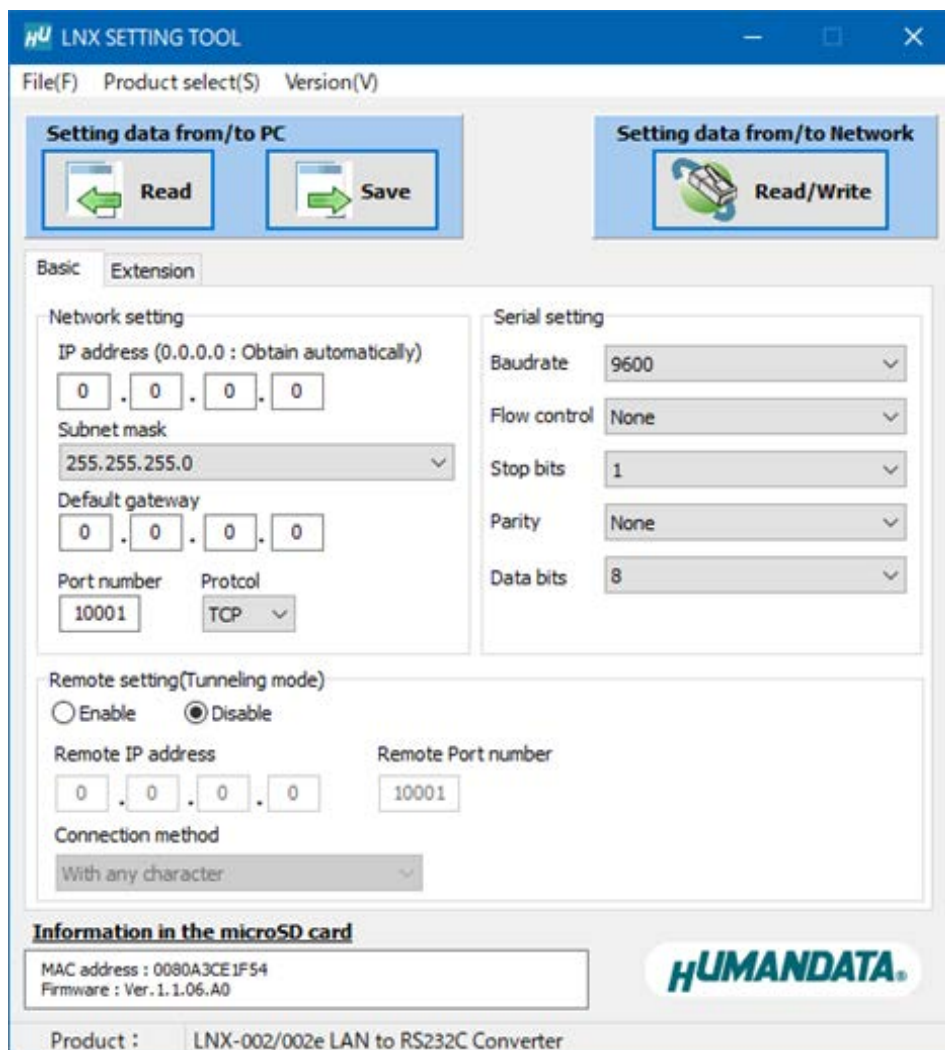

7.4. Write or Read setting data over the network

1. Enter the setting such as network or serial and click “Network”.
 - * Please confirm that microSD card is not inserted in a product.

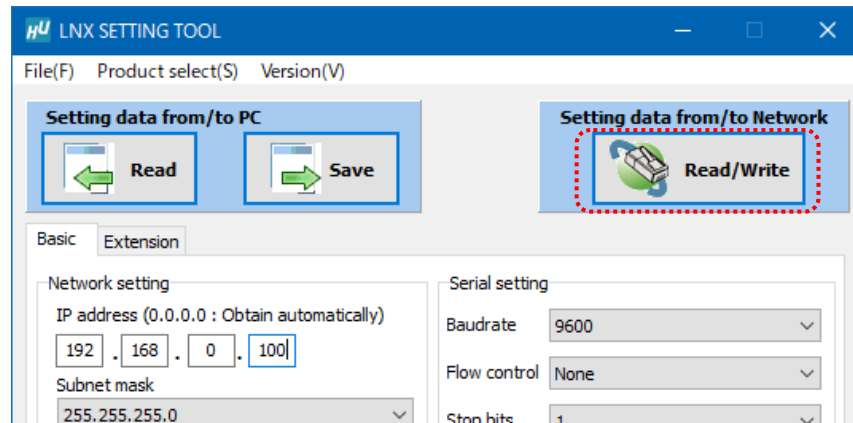

2. Enter an IP address manually or click “Search”. When some products are found, please select a number from a list.

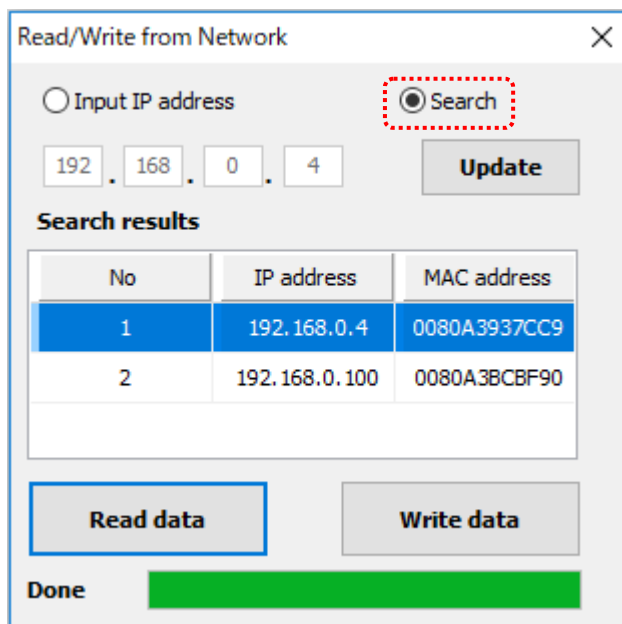

3. Click “Read data” or “Write data”
 - * Even if some devices will be listed in the list and occur process time out. In this case, please change the PCs’ network setting to the same network segment as the product or using microSD card.

7.5. Setting Example

[Tunneling mode between LNX-001 and LNX-002e]

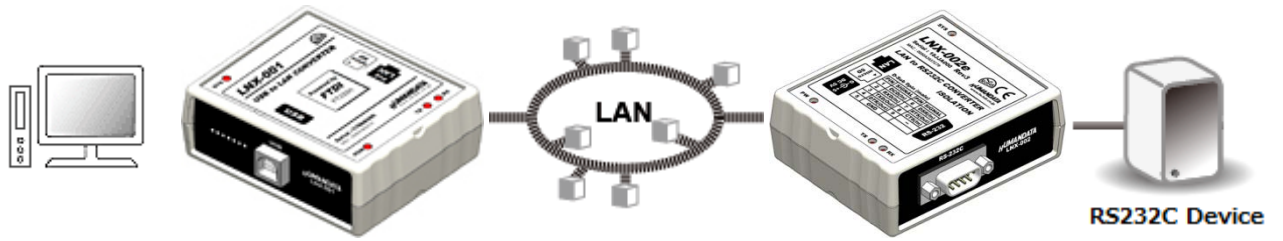

LNX-001 Side		LNX-002e Side	
Network Setting			
192.168.0.100	IP Address	192.168.0.101	
255.255.255.0	Subnet Mask	255.255.255.0	
0.0.0.0	Default Gateway	0.0.0.0	
10005	Port Number	10005	
TCP	Protocol	TCP	
192.168.0.101	Remote IP Address	192.168.0.100	
10005	Remote Port Number	10005	
Serial Communication			
230400	Baudrate	230400	
RTS/CTS (hard ware)	Flow Control	RTS/CTS (hard ware)	
1	Stop Bits	1	
None	Parity	None	
8	Data Bits	8	

[LNX-002e single operation]



LNX-002e Side

Network Setting	
IP Address	192.168.0.100
Subnet Mask	255.255.255.0
Default Gateway	0.0.0.0
Port Number	10005
Protocol	TCP
Remote IP Address	0.0.0.0
Remote Port Number	0
Serial Communication	
Baudrate	230400
Flow Control	RTS/CTS (hard ware)
Stop Bits	1
Parity	None
Data Bits	8

8. Virtual COM Port

You can use the software that creates Virtual COM ports on your PC. You can use the COM port to communicate to an IP address of LNX-002e. Rather than going out the local port, the data is transmitted across the Ethernet network using TCP/IP. LNX-002e attached to the network receives the data and transfers it from its own serial port to the attached equipment. Please refer to the "LNX series virtual COM port User's Manual" that are stored on the product supplied CD for details.

9. Additional Documentation and User Support

The following documents and other supports are available at

<https://www.hdl.co.jp/en/faspc/LNX/lrx-002/>

- Outline drawing
 - Outline drawing of the AC Adapter
 - LNX SETTING TOOL
 - External Dimension
- ... and more.

10. Warranty and compensation

Please refer to the following URL for the warranty.

<https://www.fa.hdl.co.jp/en/fa-warranty.html>

RS-232C LAN Converter
[Economy type]
LNX-002e (Rev3)
User's Manual

Ver. 3.1 Nov. 7, 2024

HuMANDATA LTD.

Address: 1-2-10-2F, Nakahozumi, Ibaraki
Osaka, Japan
ZIP 567-0034
Tel: 81-72-620-2002 (Japanese)
Fax: 81-72-620-2003 (Japanese/English)
URL: <https://www.fa.hdl.co.jp> (Japan)
<https://www.fa.hdl.co.jp/en/> (Global)
